

NETGEAR®

8800 Series Chassis Switch Hardware Installation Guide



350 East Plumeria Drive
San Jose, CA 95134
USA

February 2011
202-10803-01
v1.0

© 2011 NETGEAR, Inc. All rights reserved.

No part of this publication may be reproduced, transmitted, transcribed, stored in a retrieval system, or translated into any language in any form or by any means without the written permission of NETGEAR, Inc.

Technical Support

Thank you for choosing NETGEAR. To register your product, get the latest product updates, or get support online, visit us at <http://support.netgear.com>.

Phone (US & Canada only): 1-888-NETGEAR

Phone (Other Countries): See Support information card.

Trademarks

NETGEAR, the NETGEAR logo, ReadyNAS, ProSafe, Smart Wizard, Auto Uplink, X-RAID2, and NeoTV are trademarks or registered trademarks of NETGEAR, Inc. Microsoft, Windows, Windows NT, and Vista are registered trademarks of Microsoft Corporation. Other brand and product names are registered trademarks or trademarks of their respective holders.

Statement of Conditions

To improve internal design, operational function, and/or reliability, NETGEAR reserves the right to make changes to the products described in this document without notice. NETGEAR does not assume any liability that may occur due to the use, or application of, the product(s) or circuit layout(s) described herein.

Revision History

Publication Part Number	Version	Publish Date	Comments
202-10803-01	v1.0	February 2011	First publication

Contents

Chapter 1 About the 8800 Series Chassis Switches

Overview of the 8800 Series Chassis Switches	8
Full-Duplex Support	8
Management Ports	8
External Compact Flash Memory Card	9
8800 Series 6-slot Chassis Switch XCM8806	9
8800 Series 10-slot Chassis Switch XCM8810	11

Chapter 2 8800 Series Modules

Overview of the 8800 Series Modules	14
Supervisory Module	14
Redundant Supervisory Module Activity	14
Supervisory Module Physical Features	15
Supervisory Module LEDs	16
I/O Modules	17
8800 Series 48-port 10/100/1000 Base-T Module XCM8848T	18
8800 Series 8-port 10GBase-XFP Module XCM8808X	19
8800 Series 24-port 1000Base-X SFP Module XCM8824F	19
I/O Module LEDs	20

Chapter 3 Power Supply Units

Overview of the 100-240VAC Power Supply Unit XCM88PS1.	23
LEDs.	24
Power Supply Cords.	24
Fuse	24
Specifications	25

Chapter 4 Site Preparation

Plan Your Site.	27
Site Requirements	27
Operating Environment Requirements	27
Rack Specifications and Recommendations	31
Cable Requirements.	33
Cabling Standards	33
Cable Labeling and Record Keeping	34
Selecting Cable	34
Installing Cable	36
Radio Frequency Interference	38

Power Requirements	39
PoE Devices	39
Power Supply Requirements	39
AC Power Cord Requirements	40
Uninterruptible Power Supply Requirements	40
Applicable Industry Standards	41

Chapter 5 Install an 8800 Series Chassis

Unpack the XCM8806 Chassis	43
Unpack the XCM8810 Chassis	45
Pre-installation Requirements	48
Rack Mount the 8800 Series Chassis	48
Ground the 8800 Series Chassis	50

Chapter 6 Install Power Supply Units in the Switches

Safety	54
Power Supply Cords for AC Power Supplies	55
Install a PSU	56
Required Tools and Equipment	56
Install the 100-240VAC PSU XCM88PS1	57
Remove or Replace a PSU	58

Chapter 7 Install Modules and Establish Initial Management Access

Module Slot Assignments	61
Distinguishing a Supervisory Module from an I/O Module	61
Install an XCM8000 Series Module	62
Connect Network Interface Cables	65
Install a Backup Supervisory Module	65
Verify the Module Installation	65
Displaying Slot Status Information	66
Remove an XCM8000 Series Module	66
Blank Front Panels	68
Install a Blank Front Panel	68
Remove a Blank Front Panel	69
Install or Remove an External Compact Flash Memory Card	71
Initial Management Access	72
Connect Equipment to the Console Port	72
Logging In for the First Time	72

Chapter 8 Install or Remove Cards

Install a PoE Daughter Card XCM88P	75
Remove a PoE Card XCM88P	77
Install an Option Card XCM888F in the Supervisory Module	77
Remove a Supervisory Module Option Card	79

Chapter 9 AC Power Cord Retainers

AC Power Cord Retainer for the XCM8810 Chassis 10-slot	82
Install the Power Cord Retainer	82
Disconnect an XCM8810 Power Cord	84
Power Cord Retainer for the XCM8806 Chassis 6-Slot	84
Install the Power Cord Retainer	84
Remove the XCM8806 Power Cord Retainer	87

Chapter 10 Cable Management

Cable Management	89
Cable Holders and Cable Clips	89
Cable Holders	90
Cable Clips	92

Chapter 11 Replace 8800 Series Chassis Components

Replace the Fan Tray	93
Pre-Installation Requirements	93
Remove the Fan Tray	93
Install a Replacement Fan Tray	95
Replace the PSU/Fan Controller	97
Pre-installation Requirements	97
Remove the PSU/Fan Controller	97
Install the Replacement PSU/Fan Controller	99

Chapter 12 Repack an 8800 Series Chassis

Safety Information	102
Required Tools and Equipment	102
Repack the XCM8810 Chassis	102
Repack the XCM8806 Chassis	104

Appendix A Safety Information

Considerations Before Installing	106
Maintenance Safety	107
General Safety Precautions	107
Installing Power Supply Units	108
Selecting Power Supply Cords	109
Cable Routing for LAN Systems	110
PoE Devices	111
Battery Replacement and Disposal	111
Fiber Optic Ports—Optical Safety	111
GBIC, SFP (Mini-GBIC), XENPAK, and XFP Regulatory Compliance	112
Sicherheitshinweise	112
Installation von Netzteilen	114
Wartungssicherheit	115
Allgemeine Sicherheitsvorkehrungen	116

Auswahl der Stromkabel.	116
Austauschen und Entsorgen von Batterien	117
Lichtleiteranschlüsse: Optische Sicherheit.	117

Appendix B Technical Specifications

8800 Series Chassis Switch XCM8810	120
8800 Series Chassis Switch XCM8806	123
Modules for 8800 Series Switches	125
700 W Power Supply	126
Connector Pinouts	126

Index

About the 8800 Series Chassis Switches

1

This chapter describes the 8800 Series Chassis Switches and includes the following sections:

- *Overview of the XCM8800 Series Switches*
- *Full-Duplex Support* on page 8
- *Management Ports* on page 8
- *External Compact Flash Memory Card* on page 9
- *8800 Series 6-slot Chassis Switch XCM8806* on page 9
- *8800 Series 10-slot Chassis Switch XCM8810* on page 11

For information about installing the switches, see *Chapter 5, Install an 8800 Series Chassis*.

Overview of the 8800 Series Chassis Switches

The switches are chassis-based, Ethernet service core switches designed for core applications.

The features of these switches include:

- Hot-swappable I/O modules that include Gigabit Ethernet copper ports (10/100/1000) and Gigabit Ethernet fiber ports (SFP), or 10 Gigabit Ethernet ports (SFP+ or XFP)
- Supervisory modules that provide the active switching fabric and CPU control subsystem
- Redundant, load-sharing, hot-swappable power supplies
- Field-replaceable, hot-swappable fan trays
- Auto-negotiation for half-duplex or full-duplex operation on 10/100/1000 Mbps ports
- Load sharing on multiple ports

The 8800 series switches include two chassis models:

- NETGEAR 8800 Series Chassis Switch XCM8806, with slots for installing one or two Supervisory modules and up to five I/O modules
- NETGEAR 8800 Series Chassis Switch XCM8810, with slots for installing one or two Supervisory modules and up to nine I/O modules

The modules for the 8800 series switches provide high port density and scalability for mid-sized networks.

The specific capabilities of the switch are determined by the module series installed in the chassis. For more information about individual I/O modules and Supervisory modules, see [Chapter 2, 8800 Series Modules](#).

For more information about configuring a switch, see the *NETGEAR 8800 Series Chassis Switch User Manual* and the *NETGEAR 8800 Series Chassis Switch CLI Manual*.

Full-Duplex Support

The switches provide full-duplex support for all ports. Full-duplex support means that frames can be transmitted and received simultaneously, effectively doubling the bandwidth available on a link. Most ports on a switch auto-negotiate duplex operation in the default configuration. Gigabit Ethernet fiber ports and 10-Gigabit Ethernet ports operate only in full-duplex mode in accordance with technical standards.

Management Ports

Each Supervisory module has a 10/100BASE-TX Ethernet management port. This port allows you to communicate directly with the central processing unit (CPU) of the switch. You can plug an Ethernet cable directly from your laptop into the management port for direct

access into the switch. This access allows you to view and locally manage the switch configurations.

External Compact Flash Memory Card

Supervisory modules include a compact flash slot next to the console port. This slot accepts a compact flash memory card, which can be used to download a new version of software and for other functions, including capturing debug information and core dump files. See the *NETGEAR 8800 Series Chassis Switch User Manual* for more information regarding the use of the external compact flash memory card.

The external compact flash slot supports third-party compact flash cards.

Note: You have to use an industrial-grade compact flash card in the external compact flash slot of the Supervisory module.

8800 Series 6-slot Chassis Switch XCM8806

The chassis includes the following physical features:

- One 6-slot chassis with backplane
- Four dedicated I/O module slots, labeled 1, 2, 5, and 6
- One dedicated Supervisory module slot, labeled 3/A
- One dual-use slot for either an I/O module or Supervisory module, labeled 4/B.
- Power supply bay that accommodates up to six power supplies, accessed from the front of the unit
- One fan tray, accessed from the front right of the unit
- One connector for an ESD-preventive wrist strap

Depending on the Supervisory modules and I/O modules installed, the XCM8806 chassis can support up to 48 gigabits per second of bandwidth per slot.

The following figure shows the front of a XCM8806 chassis equipped with two Supervisory modules and three I/O modules.

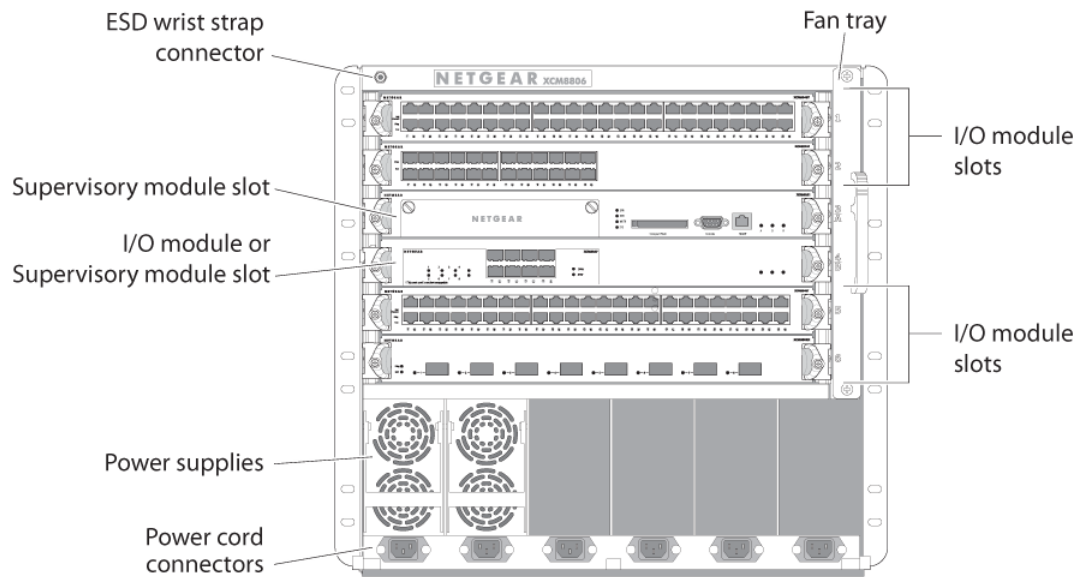

Figure 1. Front of the XCM8806 Chassis

The following figure shows the rear panel of the XCM8806 chassis.

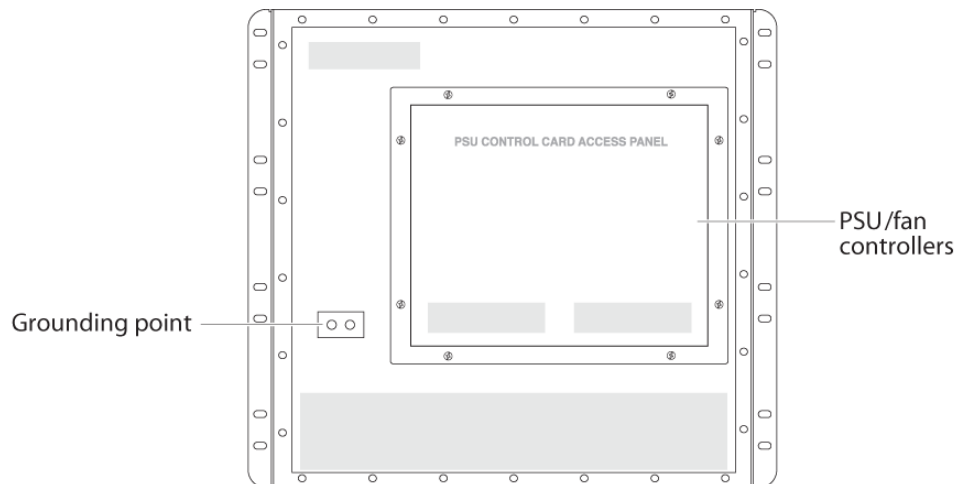

Figure 2. Rear panel of the XCM8806 Chassis

The rear panel of the XCM8806 chassis provides:

- Chassis serial number
- Ethernet MAC address of the switch
- Symbols of safety certification
- Access to the PSU/fan controllers
- Attachment point for optional chassis ground

8800 Series 10-slot Chassis Switch XCM8810

The XCM8810 chassis includes the following physical features:

- One 10-slot chassis with backplane
- Eight dedicated I/O module slots, labeled 1, 2, 3, 4, 7, 8, 9 and 10
- One dedicated Supervisory module slot, labeled 5/A
- One dual-use slot for an I/O module or Supervisory module, labeled 6/B.
- Power supply bay that accommodates up to six power supplies, accessed from the front of the unit
- One fan tray, accessed from the front right of the unit
- One connector for an ESD-preventive wrist strap

Depending on the Supervisory modules and I/O modules installed, the XCM8810 chassis can support up to 48 gigabits per second of bandwidth per slot.

The following figure shows the front of a XCM8810 chassis equipped with two Supervisory modules and three I/O modules.

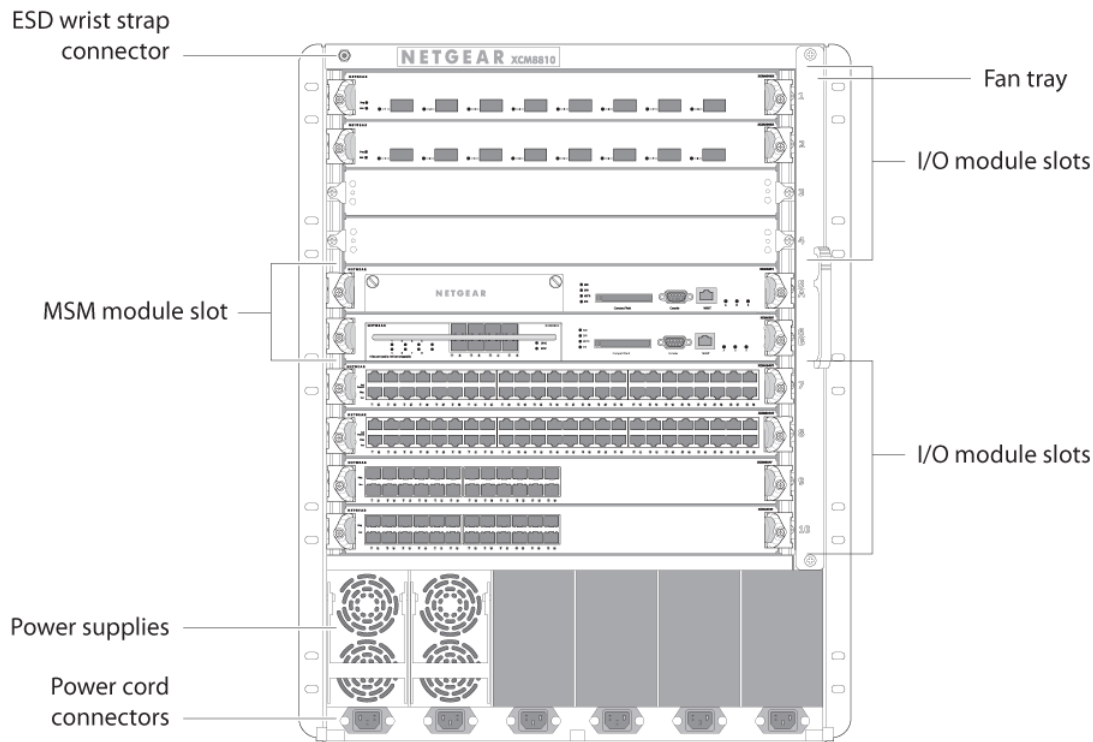

Figure 3. Front of the XCM8810 Chassis

The following figure shows the rear panel of the XCM8810 chassis.

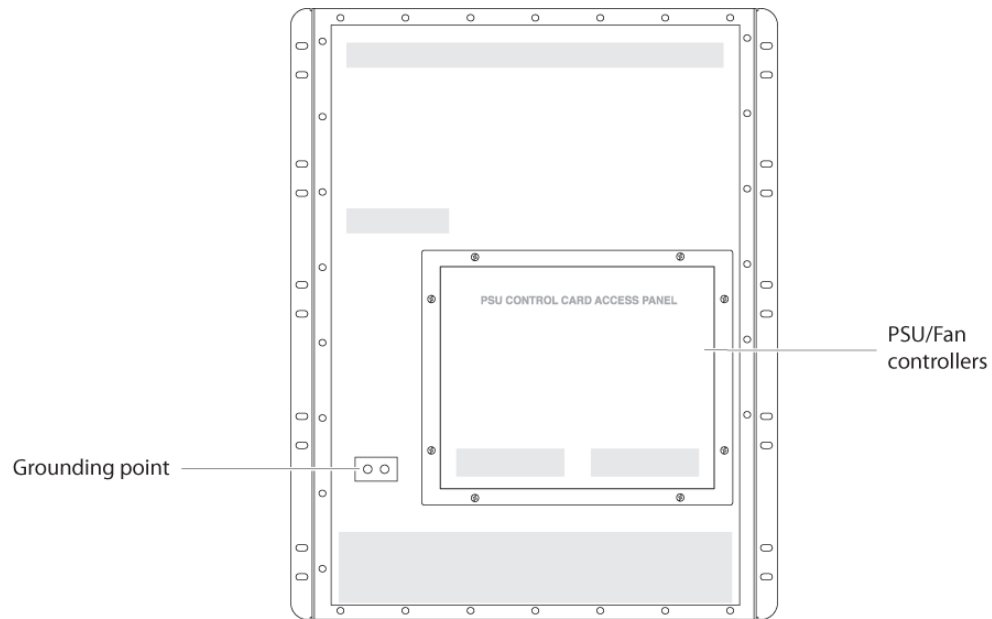

Figure 4. Rear panel of the XCM8810 Chassis

The rear panel of the XCM8810 chassis provides:

- Chassis serial number
- Ethernet MAC address of the switch
- Symbols of safety certification
- Access to the PSU/fan controllers
- Attachment point for optional chassis ground

2 8800 Series Modules

2

This chapter describes modules for the 8800 series switches and includes the following sections:

- *Overview of the 8800 Series Modules* on page 14
- *Supervisory Module* on page 14
- *I/O Modules* on page 17

Overview of the 8800 Series Modules

Supervisory modules and I/O modules are available. A module consists of a printed circuit board mounted on a metal panel that acts as the insertion vehicle in the 8800 series switches. The module carrier also includes ejector/injector levers and captive retaining screws at each end of the module front panel. LEDs on the module front panel provide information about the operating status of the modules.

The 8800 series switches support these modules:

- 8800 Series Supervisory Module XCM88S1
- 8800 Series 48-port 10/100/1000 Base-T Module XCM8848T
- 8800 Series 24-port 1000Base-X SFP Module XCM8824F
- 8800 Series 8-port 10GBase-XFP Module XCM8808X

Supervisory Module

The Supervisory module provides the active switching fabric and CPU control subsystem for the switch. One Supervisory module is required for switch operation; however, adding a second Supervisory module to the chassis increases reliability and throughput.

A compact flash slot allows you to insert an external compact flash memory card. (See [External Compact Flash Memory Card](#) on page 9 for more information about supported compact flash cards.)

Redundant Supervisory Module Activity

The 8800 series switches can run with a single Supervisory module installed. When you install an additional Supervisory module, one Supervisory module operates as the primary Supervisory module and the other becomes the backup (secondary) Supervisory module. The primary Supervisory module is responsible for upper-layer protocol processing and system management functions. Packet handling is distributed among the CPUs of all installed Supervisory modules.

When you save the switch configuration, it is saved to all Supervisory modules.

Selection of the primary Supervisory module occurs automatically. The following examples describe the selection process:

- When a switch boots with two Supervisory modules installed, the Supervisory module in the lower-numbered slot becomes the primary Supervisory module. In the XCM8810 switch this is slot 5; in the XCM8806 switch, this is slot 3.
- When a switch boots with a single Supervisory module (regardless of the slot position), it is selected as the primary Supervisory module.

If a second Supervisory module is added to the switch after it has been powered up, the added Supervisory module becomes the backup Supervisory module. Supervisory

modules that operate as backup Supervisory modules can be inserted and removed without disrupting network services.

- If you remove the primary Supervisory module while the switch is operating, the backup Supervisory module performs a soft reset and then becomes the primary Supervisory module.

For example, in an 8800 Series Chassis Switch XCM8810 with a primary Supervisory module in slot 5 and a backup Supervisory module in slot 6, if you remove the primary Supervisory module from slot 5, the backup Supervisory module in slot 6 becomes the primary Supervisory module.

Supervisory Module Physical Features

The following figure shows the Supervisory module.

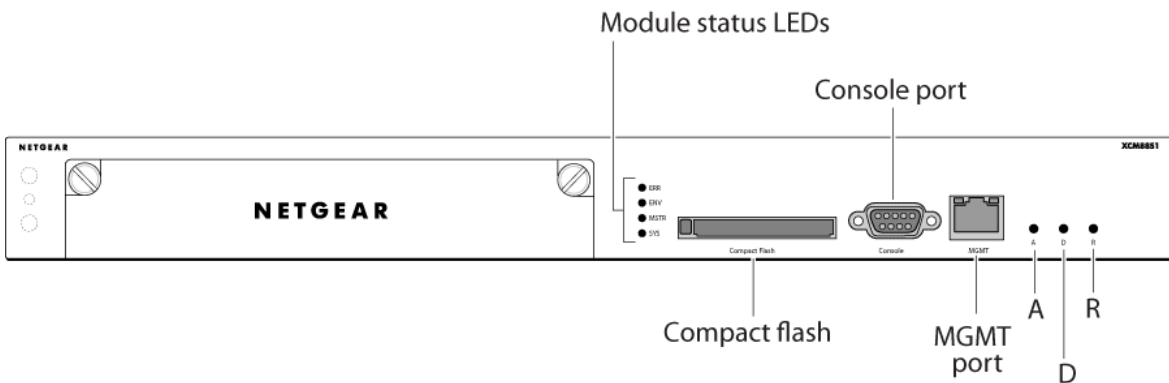

Figure 5. Supervisory module

The Supervisory module has the following features on the front panel:

- Module status LEDs
- Compact flash slot
- Console port. DB-9 serial port used to connect a terminal and perform local management.
- Management port. A 10/100 Mbps Ethernet management port used to connect an Ethernet cable directly from your laptop to the switch to view and locally manage the switch configurations. This port can also be used to connect the system into a parallel management network for administration.
- A button. Allows you to select the alternate BootROM image when you power on the module. To use the alternate BootROM image, simultaneously hold the **A** button while pressing the **R** button.
- D button. Allows you to force a system dump that dumps the debug information into NVRAM. This information is available on the next reboot. No core file is created.
- R button. Allows you to reset the Supervisory module without removing the module from the chassis.

The Supervisory module has a slot for the XCM888F option card, which adds eight 1-gigabit SFP data ports to the Supervisory module. These data ports operate the same as the ports on the 24 G SFP module. (See [8800 Series 24-port 1000Base-X SFP Module XCM8824F](#) on page 19 for more information.)

Note: See the *NETGEAR 8800 Series Chassis Switch User Manual* and the *NETGEAR 8800 Series Chassis Switch CLI Manual* for more information about numbering conventions for the modules and ports, as well as configuration and display information.

Supervisory Module LEDs

The following table describes the LED activity on the Supervisory module.

Table 1. Supervisory Module LEDs

LED	Color	Indicates
ERR	Amber	A critical software error has been logged since power-up.
	Off	Normal operation is occurring.
ENV	Green	Environment (temperature, fan, power supply) is operating properly.
	Amber	Environmental failure has occurred.
MSTR or MSTR/DIAG	Green	Module is operating as primary Supervisory module.
	Amber	Module is operating as backup (secondary) Supervisory module.
	Green blinking	Power-on self-test (POST) is running.
	Off	Normal operation for diagnostics.
SYS or SYS/STA	Green blinking	Normal operation is occurring.
	Amber blinking	Diagnostic tests are running on the module. The LED resets if the diagnostics are terminated. The LED returns to flashing amber if another diagnostic test is started.
	Amber	Diagnostic failure has occurred.
	Off	Switch is not receiving power.
Link on MSTR Ethernet port	Green	Link is up.
	Off	Link is down.

Note: The LEDs on the management Ethernet port are not labeled. The left LED indicates link status, and the right LED indicates link activity by blinking green.

I/O Modules

The 8800 series of I/O modules consists of the following:

- *8800 Series 48-port 10/100/1000 Base-T Module XCM8848T* on page 18
- *8800 Series 8-port 10GBase-XFP Module XCM8808X* on page 19
- *8800 Series 24-port 1000Base-X SFP Module XCM8824F* on page 19

No configuration information is stored on the I/O modules; all configuration information is stored on the Supervisory modules.

When an 8800 series switch is powered on, the software generates a default configuration for any slots that contain I/O modules. The default configuration allows the I/O module ports to participate in the VLAN named *default*. The default configuration for the I/O module is not preserved unless you explicitly save the configuration to NVRAM.

You can configure parameters of an I/O module after it is installed, or preconfigure a slot for a certain type of module and configuration. The preconfigured information is applied to the module after it is inserted. If you preconfigure a slot for a specific module type and then insert a different type of module, the inserted module does not become operational because of the mismatch. If this situation occurs, the `show slot` command shows the module state as `mismatch`.

Note: See the *NETGEAR 8800 Series Chassis Switch User Manual* and the *NETGEAR 8800 Series Chassis Switch CLI Manual* for feature-specific information related to XCM8000 series modules.

8800 Series 48-port 10/100/1000 Base-T Module XCM8848T

This module has 48 autosensing 10/100/1000BASE-T ports that use standard RJ-45 connectors.

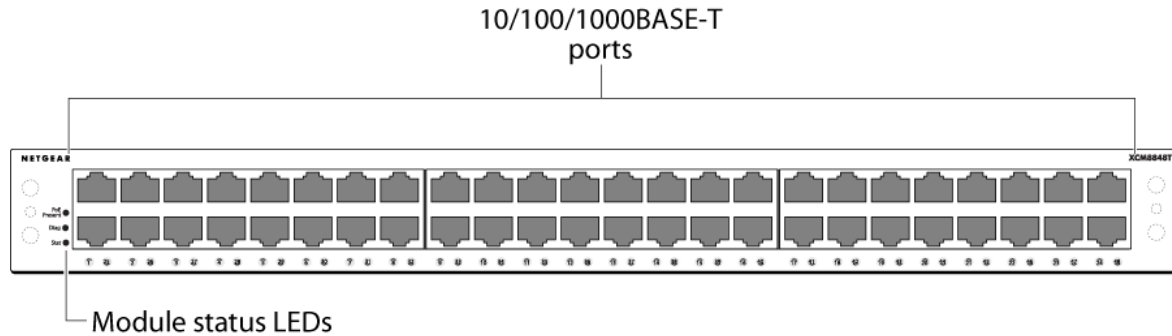

Figure 6. 8800 Series 48-port 10/100/1000 Base-T Module XCM8848T

You can add an optional PoE daughter card (XCM88P) to the 48 G Copper module to provide Power over Ethernet (PoE) functions in this module. With an installed PoE card, the ports can deliver PoE to an attached device, as well as the usual Ethernet connection, using a single cable. The 48 G Copper module supports the IEEE 802.3af PoE specification.

In the default configuration of the XCM8848T module I/O module, all ports:

- Are added to the default VLAN as untagged
- Inherit the properties of the default VLAN (for example, protocol type and VLANid)
- Operate in autonegotiation mode

The XCM8848T module has the following LEDs:

- Module status
- Module diagnostics
- Port status
- PoE present

For information about the LEDs and their activity on the module, see [I/O Module LEDs](#) on page 20.

8800 Series 8-port 10GBase-XFP Module XCM8808X

This module has eight unpopulated XFP-based 10-gigabit Ethernet ports.

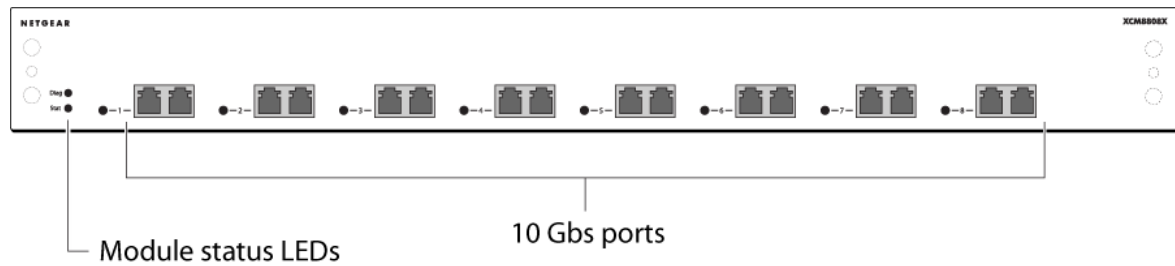

Figure 7. 8800 Series 8-port 10GBase-XFP Module XCM8808X

In the default configuration of the 8800 Series 8-port 10GBase-XFP Module, all ports:

- Are added to the default VLAN as untagged
- Inherit the properties of the default VLAN (for example, protocol type and VLANid)

The 8800 Series 8-port 10GBase-XFP Module has the following LEDs:

- Module status
- Module diagnostics
- Port status

For information about the LEDs and their activity on the 8 10G XFP module, see [I/O Module LEDs](#) on page 20.

8800 Series 24-port 1000Base-X SFP Module XCM8824F

This module has 24 unpopulated SFP-based 1-gigabit Ethernet ports.

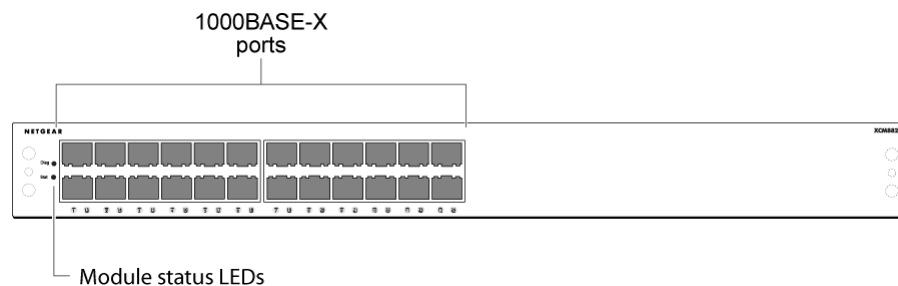

Figure 8. 8800 Series 24-port 1000Base-X SFP Module XCM8824F

In the default configuration of the 8800 Series 24-port 1000Base-X SFP Module, all ports:

- Are added to the default VLAN as untagged
- Inherit the properties of the default VLAN (for example, protocol type and VLANid)

The 8800 Series 24-port 1000Base-X SFP Module module has the following LEDs:

- Module status
- Module diagnostics
- Port status

For information about the LEDs and their activity, see the following section, [I/O Module LEDs](#).

I/O Module LEDs

This section describes the LEDs for the module, the port, and inline power delivery status for I/O modules in the 8800 series of switches.

Note: Inline power delivery applies only to the ports on an 8800 Series 48-port 10/100/1000 Base-T Module XCM8848T with an installed PoE card.

Module LEDs

The following table describes the LED activity for all I/O modules that are installed in 8800 series switches.

Table 2. LED Meanings in I/O Modules for 8800 Series Switches

LED	Color	Indicates
PoE Present	Amber	The optional PoE card is installed on the module but is malfunctioning.
	Green	The optional PoE card is installed on the module and is active.
	Off	No optional PoE card is installed.
	This LED is present only on the XCM8848T module.	
Status	Green blinking	Normal operation
	Amber blinking	Configuration error, code version error, diagnostic failure, or other severe module error
	Off	No power
DIAG	Off	Normal operation
	Amber blinking	Diagnostics in progress
	Amber	Diagnostic failure

Port LEDs on Non-PoE Modules

The following table describes the LED meanings for each port on the non-PoE XCM8000 series I/O modules and the port option card for the Supervisory module. These include the following modules and option card:

- 8800 Series 48-port 10/100/1000 Base-T Module XCM8848T (without PoE card)
- 8800 Series 24-port 1000Base-X SFP Module XCM8824F
- 8800 Series 8-port 10GBase-XFP Module XCM8808X
- 8800 Series SFP Card XSM88F for Supervisory module

Table 3. Port LEDs for Non-PoE I/O Modules and Port Option Card

Port LED Color	Indicates
Solid green	Link up
Slow green blinking	Port disabled
Amber blinking	Activity
Off	Link down

This table describes port LED activity for the XCM8848T modules without an installed PoE card.

Port LEDs on the XCM8848T Module with a PoE Card

The following table describes the port LEDs for the XCM8848T module with an installed PoE card. When the PoE card is installed, the port LEDs indicate the status of the inline power delivered through the ports.

Table 4. Port LEDs for the XCM8848TT Module with a PoE Card (XCM88P)

LED	Color and State	Meaning
Port with power enabled	Solid amber	Link up
	Amber blinking	Activity
	Slow amber blinking	Port disabled or Link down
	Blinking amber/green	Power fault or insufficient power
Port with power disabled	Solid green	Link up
	Slow green blinking	Port disabled
	Green blinking	Activity
	Off	Link down
	Blinking amber/green	Power fault or insufficient power

3 Power Supply Units

3

The XCM8800 Series Chassis Switch are powered by 100-240VAC Power Supply Units (PSUs). AC power supplies in the 8800 series switches are fully fault tolerant and load-sharing in an N+1 configuration. After the system is properly configured, if one PSU fails, the others will provide sufficient power to operate a fully loaded switch.

This chapter includes the following sections:

- *Overview of the 100-240VAC Power Supply Unit XCM88PS1* on page 23
- *LEDs* on page 24
- *Power Supply Cords* on page 24
- *Fuse* on page 24
- *Specifications* on page 25

Overview of the 100-240VAC Power Supply Unit XCM88PS1

The following figure shows the 100-240VAC UL-listed accessory power supply unit (PSU). The power supply bay in a 8800 series switch can accommodate up to six hot-swappable PSUs.

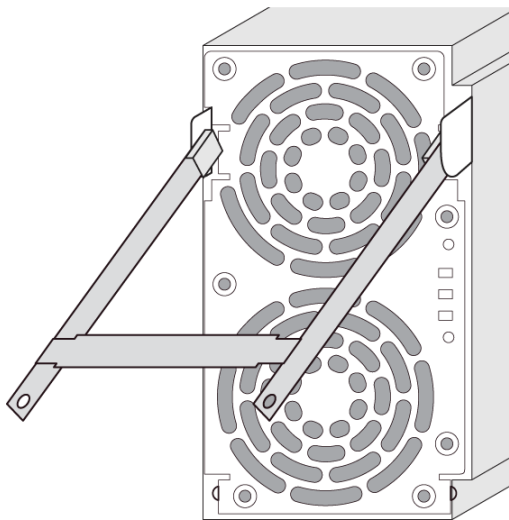

Figure 9. Power Supply Unit XCM88PS1

The front panel on each PSU provides a handle for insertion and removal of the unit. Two cooling fans draw air in through the front vents on the PSU and exhaust the air through the rear vents of the switch. Airflow through the PSU is independent from the airflow through the rest of the switch.

The AC input connection is located on the switch directly below each installed power supply.





WARNING!

Field operators must not attempt to open the PSU enclosure for any reason; the PSU does not contain user-serviceable parts. In the event of failure, return the defective PSU for repair or replacement.

LEDs

The front panel of the PSU provides status LEDs. The following table describes the LED activity.

Table 5. LEDs on the PSU

PSU Condition	Power  Green	Predictive Fail  Amber	Fail  Amber
Power supply AC outputs working normally	On	Off	Off
AC input power present/standby output on	Blinking	Off	Off
Current limit on 48 VDC output	On	Off	Blinking
Predictive failure	On	Blinking	Off
No input power to this PSU only	Off	Off	On
No input power to any PSU	Off	Off	Off
Power supply failure	Off	Off	On

Power Supply Cords

The PSU(s) can be used with either a 110 V AC or a 220 V AC power supply cord. If you use a 110 V AC power supply cord, the maximum DC output power of the PSU is 700 W. If you use a 220V AC power supply cord the maximum DC output power of the PSU is 1200 W.

Should you use your own, all power supply cords have to meet the requirements listed in [Selecting Power Supply Cords](#) on page 109.

Fuse

The PSU line and neutral legs are both fused. Power to the switch may still be live if the neutral fuse is open. This is not a field operator replaceable fuse. In the event of failure, immediately return the PSU for a complete replacement.



WARNING!

Field operators must not attempt to configure or replace fuses in PSUs! In the event of failure, immediately return the defective PSU for a complete replacement.

Specifications

The XCM88PS1 PSU functions from 90 V to 264 V and 47 Hz to 63 Hz AC Input. Each PSU provides 700 W to the system if the AC input is in the 110 V low-line output power range and 1200 W to the system if the AC input is in the 220 V high-line output power range.

More installed PSUs are needed to support the load if the low-line power range is used to power the switch. The software determines the maximum available power required for the switch and enables the modules accordingly.



CAUTION:

The PSU does not have a switch for turning the unit on and off. Remove the plug from the electrical outlet to disconnect power to the PSU. Make sure that this connection is easily accessible.

Make sure that the PSU circuit is not overloaded. Use proper over-current protection, such as a circuit-breaker, to prevent over-current conditions.

4 Site Preparation

4

This chapter includes the following sections:

- *Plan Your Site* on page 27
- *Site Requirements* on page 27
- *Cable Requirements* on page 33
- *Power Requirements* on page 39
- *Applicable Industry Standards* on page 41

The information in this chapter is intended for the system administrator, network equipment technician, network manager, or facilities manager responsible for installing and managing the network hardware. The chapter assumes a working knowledge of local area network (LAN) operations and a familiarity with communications protocols that are used on interconnected LANs.

Note: Before installing or removing any components of the system, or before carrying out any maintenance procedures, read the safety information provided in *Appendix A, Safety Information*.

Plan Your Site

By carefully planning your site, you can maximize the performance of your existing network and ensure that it is ready to migrate to future networking technologies. The site planning process has three major parts:

- Meeting site requirements

The physical installation site has to meet the following requirements for a safe and successful installation:

- Building and electrical code requirements
- Environmental, safety, and thermal requirements for the equipment you plan to install
- Equipment rack requirements

- Evaluating and meeting cable requirements

After examining your physical site and verifying that all environment requirements are met, evaluate and compare your existing cable plant with the requirements of the equipment to determine if you need to install new cables.

- Meeting power requirements

To run your equipment safely, you have to meet the specific power requirements for each power supply unit installed in the system. For power supply specifications, see [700 W Power Supply](#) on page 126.

Site Requirements

This section describes requirements to consider when preparing your installation site, including:

- [Operating Environment Requirements](#) on page 27
- [Rack Specifications and Recommendations](#) on page 31

Operating Environment Requirements

Verify that your site meets all environmental and safety requirements.

Virtually all areas of the United States are regulated by building codes and standards. During the early planning stages of installing or modifying your LAN, it is important that you develop a thorough understanding of the regulations that pertain to your location and industry.

Building and Electrical Codes

Building and electrical codes vary depending on your location. Comply with all code specifications when planning your site and installing cable. The following sections are provided as a resource to obtain additional information.

Information about major building codes is located at the following websites:

- International Code Council (ICC); 5203 Leesburg Pike; Falls Church, Virginia 22041 USA.
<http://www.iccsafe.org>
<http://www.sbcci.org>

Five authorities on electrical codes are:

- National Electrical Code (NEC) Classification (USA only)—a recognized authority on safe electrical wiring. Federal, state, and local governments use NEC standards to establish their own laws, ordinances, and codes on wiring specifications. The NEC classification is published by the National Fire Protection Association (NFPA). The address is NFPA; 1 Batterymarch Park; Quincy, Massachusetts 02169 USA. <http://www.nfpa.org>.
- Underwriters' Laboratory (UL) (USA only)—an independent research and testing laboratory. UL evaluates the performance and capability of electrical wiring and equipment to determine whether they meet certain safety standards when properly used. Acceptance is usually indicated by the words "UL Approved" or "UL Listed." The address is UL; 333 Pfingsten Road; Northbrook, Illinois 60062-2096 USA. <http://www.ul.com>.
- National Electrical Manufacturing Association (NEMA) (USA only)—an organization of electrical product manufacturers. Members develop consensus standards for cables, wiring, and electrical components. The address is NEMA; 1300 N. 17th Street; Rosslyn, Virginia 22209. <http://www.nema.org>.
- Electronics Industries Alliance (EIA)—a trade association that develops technical standards, disseminates marketing data, and maintains contact with government agencies in matters relating to the electronics industry. The address is EIA; 2500 Wilson Boulevard; Arlington, Virginia 22201 USA. <http://www.eia.org>.
- Federal Communications Commission (FCC) (USA only)—a commission that regulates all interstate and foreign electrical communication systems that originate in the United States according to the Communications Act of 1934. The FCC regulates all U.S. telephone and cable systems. The address is FCC; 445 12th Street S.W.; Washington, D.C. 20554 USA. <http://www.fcc.gov>.

Wiring Closet Considerations

Be aware of the following recommendations for your wiring closet:

- Be sure that your system is easily accessible for installation and service. See [Rack Specifications and Recommendations](#) on page 31 for information.
- Use appropriate AC or DC power, power distribution, and grounding for your specific installation.
- Use a vinyl floor covering in your wiring closet. (Concrete floors accumulate dust, and carpets can cause static electricity.)
- Prevent unauthorized access to wiring closets by providing door locks. Install the equipment in a secured, enclosed, and restricted access location, ensuring that only qualified service personnel have access to the equipment.
- Provide adequate overhead lighting for easy maintenance.

- Be sure that each wiring closet has a suitable ground. All distribution racks and equipment installed in the closet should be grounded.
- Be sure that all system environmental requirements are met, such as ambient temperature and humidity.

Note: NETGEAR recommends that you consult an electrical contractor for commercial building and wiring specifications.

Temperature

This equipment generates a significant amount of heat. It is essential that you provide a temperature-controlled environment for both performance and safety.

Install the equipment only in a temperature- and humidity-controlled indoor area that is free of airborne materials that can conduct electricity. Too much humidity can cause a fire. Too little humidity can produce electrical shock and fire.

Follow these general thermal recommendations for your wiring closet:

- Be sure that the ventilation in the wiring closet is adequate to maintain a temperature below 104° F (40° C).
- Install a reliable air conditioning and ventilation system.
- Keep the ventilation in the wiring closet running during non-business hours; otherwise, the equipment can overheat.
- Maintain an ambient operating temperature of 32° to 104° F (0° to 40° C).
- Maintain a storage temperature of -40° to 158° F (-40° to 70° C).

Note: As with all electrical equipment, your product lifetime can degrade with increased temperature. If possible, keep temperatures at approximately 78° F (25° C) or lower.

Humidity

To maximize equipment life, keep operating humidity between 50% and 70% relative humidity (non-condensing) during typical operation. The equipment can operate between 10% and 95% relative humidity (non-condensing) for short intervals.

Chassis Spacing Requirements

NETGEAR recommends placing no more than three chassis next to each other because of to chassis-to-chassis heating. Use the following spacing guidelines when you install your 8800 series switch:

- Leave a minimum of one empty 19-inch rack between two sets of three adjacent switches.

or

- Place patch panels between two sets of three adjacent switches. A patch panel does not require any power and does not generate any heat.

Note: Up to five adjacent switches will continue to function without safety concerns. However, product lifetime may degrade with continued exposure to high temperatures in close proximity, and long term reliability may be compromised.

Chassis Airflow Requirements

To ensure proper airflow through a switch, refer to the following recommendations when you install the switch:

- 8800 series switches require a minimum of 1.5 inches (4 cm) around both the left and right sides of the chassis from any cabinet wall or other obstruction for proper airflow.
- Air temperature measured approximately 1 inch (2.5 cm) from the fan inlet should be less than 104 °F (40 °C).

In the 8800 series switches, air moves through the power supplies independently of the airflow through the modules, as shown in the following figure.

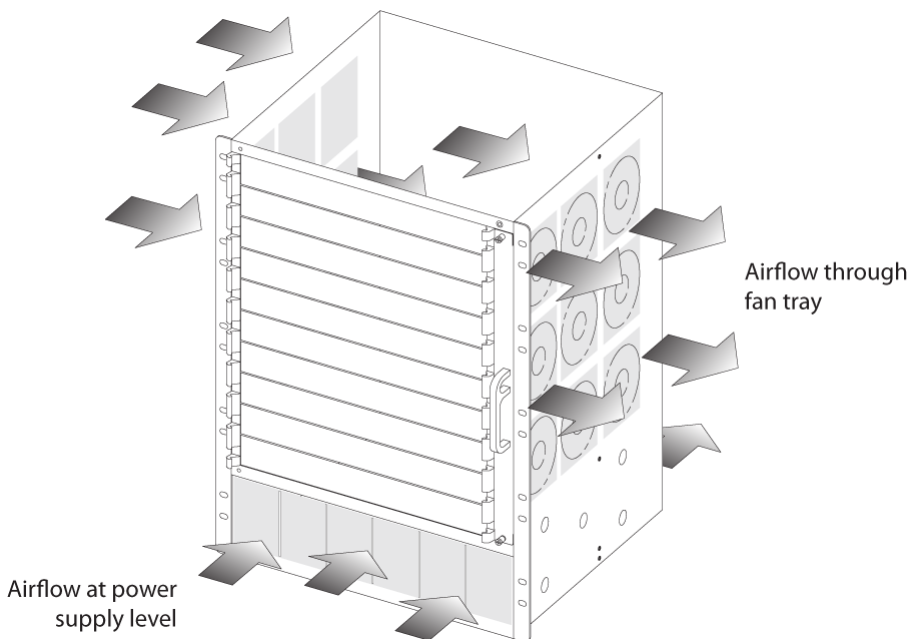

Figure 10. Airflow through the XCM8810 Chassis

Electrostatic Discharge

Your system has to be protected from static electricity or electrostatic discharge (ESD). Take the following measures to ensure optimum system performance:

- Remove materials that can cause electrostatic generation (such as synthetic resins) from the wiring closet. Check the appropriateness of floor mats and flooring.
- Connect metal chassis, conduit, and other metals to ground using dedicated grounding lines.
- Use electrostatically safe equipment and the ESD-preventive wrist strap that is provided with your equipment. All switches have ESD-preventive wrist strap connectors and are shipped with an ESD-preventive wrist strap as shown in the following figure.

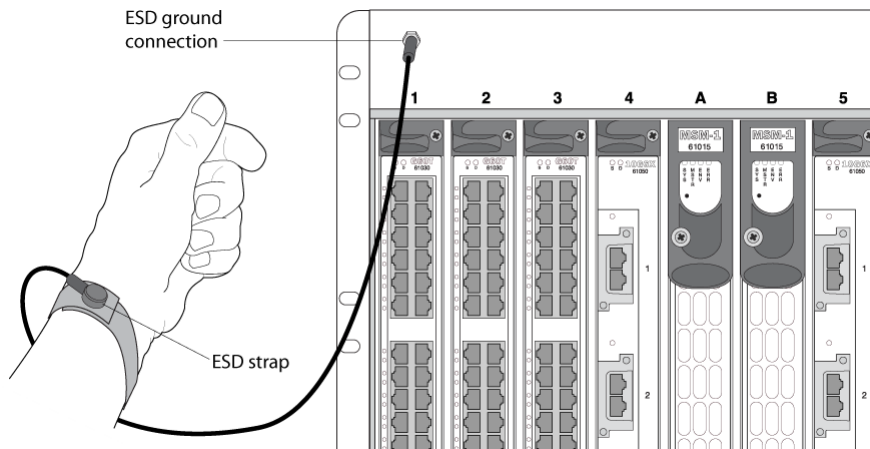

Figure 11. Using an ESD-preventive wrist strap

Rack Specifications and Recommendations

Racks should conform to conventional standards. In the United States, use EIA Standard RS-310C: Racks, Panels, and Associated Equipment. In countries other than the United States, use IEC Standard 297. In addition, verify that your rack meets the basic mechanical, space, and earthquake requirements that are described in this section.

Mechanical Recommendations for the Rack

Use equipment racks that meet the following mechanical recommendations:

- Use an open style, 19-inch rack to facilitate easy maintenance and to provide proper ventilation.
- Use a rack made of steel or aluminum.
- The rack should use the universal mounting rail hole pattern that is identified in IEC Standard 297.
- The rack should have designated earth grounding connections (typically on the base).
- The rack needs to meet earthquake safety requirements equal to that of the installed chassis.
- The mounting holes should be flush with the rails to accommodate the chassis.
- The rack should support approximately 600 pounds (272 kilograms).

Protective Grounding for the Rack

Use a rack grounding kit and a ground conductor that is carried back to earth or to another suitable building ground.

All switches are designed with mounting brackets that provide solid metal-to-metal connection to the rack. If you do not use equipment racks, you can attach wiring terminals directly to the mounting brackets for appropriate grounding. The switches have grounding terminals that are mounted on the back of the chassis.

At a minimum, follow these guidelines to ground equipment racks to the earth ground:

- CAD weld appropriate wire terminals to building I-beams or earth ground rods.
- Use the appropriate chassis grounding wire for your system, which is dependant upon the available input current to the power supply.
 - For AC systems using a 20A breaker per PSU (SSI AC), the chassis ground can be as small as 14 AWG. The power cable ground should be the same size as the primary.
 - For DC systems using a 15A breaker per PSU, the chassis ground can be as small as 14 AWG. The power cable ground should be the same size as the primary.
 - For DC systems using a 40A breaker per PSU (SSI DC), the chassis ground can be as small as 10 AWG. The power cable ground should be the same size as the primary.

Note: For complete details on power supplies and power supply cords, refer to the following: [Chapter 3, Power Supply Units](#) and [Appendix A, Selecting Power Supply Cords](#).

- Drill and tap wire terminals to equipment racks.
- Position the earth ground as close to the equipment rack as possible to maintain the shortest wiring distance possible.
- Use a ground impedance tester or micro-ohm meter to test the quality of earth ground connection at the chassis. This will insure good grounding between the chassis, rack, and earth ground.

Note: *Because building codes vary worldwide, NETGEAR strongly recommends that you consult an electrical contractor to ensure proper equipment grounding for your specific installation.*

Space Requirements for the Rack

Provide enough space in front of and behind the switch so that you can service it easily. Allow a minimum of 48 inches (122 cm) in front of the rack and 24 inches (61 cm) behind the rack. When using a relay (two-post) rack, provide a minimum of 24 inches (61 cm) of space behind the mounted equipment. Extra room on each side is optional.

Securing the Rack

The rack should be attached to the wiring closet floor with 3/8-inch (9.5 mm) lag screws or equivalent hardware. The floor under the rack should be level within 3/16-inch (5 mm). Use a floor-leveling cement compound if necessary or bolt the racks to the floor as shown in the following figure.

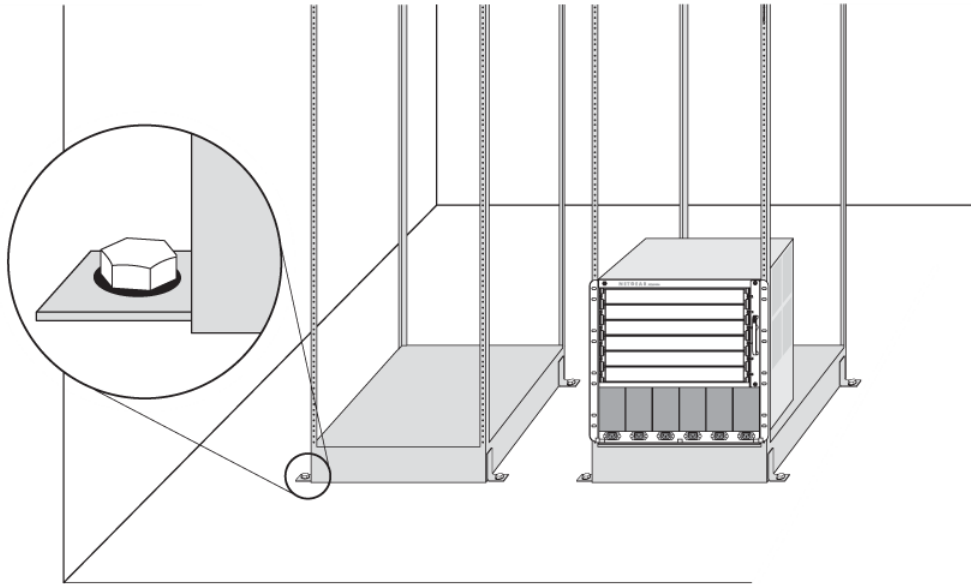

Figure 12. Correctly secured rack

Brace open equipment racks if the channel thickness is less than 1/4 inch (6.4 mm).

Cable Requirements

This section describes requirements for the cable you should use when installing your network equipment. It includes:

- *Cabling Standards* on page 33
- *Cable Labeling and Record Keeping* on page 34
- *Selecting Cable* on page 34
- *Installing Cable* on page 36
- *Radio Frequency Interference* on page 38

Cabling Standards

NETGEAR recommends using the Building Industry Consulting Service International (BICSI) Registered Communications Distribution Designer (RCDD), which is globally recognized as a standard in site planning and cabling. For information, go to:

<http://www.bicsi.org>

Cable Labeling and Record Keeping

A reliable cable labeling system is essential when planning and installing a network. Maintaining accurate records helps you to:

- Relocate devices easily.
- Make changes quickly.
- Isolate faults in the distribution system.
- Locate the opposite end of any cable.
- Know the types of network devices that your cabling infrastructure can support.

Consider the following recommendations when setting up a cable labeling system suitable for your installation:

- Identify cables by securely attaching a label to all cable ends.
- Assign a unique block of sequential numbers to the group of cables that run between each pair of wiring closets.
- Assign a unique identification number to each distribution rack.
- Identify all wiring closets by labeling the front panel of your equipment and other hardware.
- Keep accurate and current cable identification records.
- Post records near each distribution rack. Include the following cable drop information:
 - Cable source
 - Cable destination
 - Jumper location

Selecting Cable

This section provides information that is helpful when you select the cables to be used with the 8800 series switch.

Cable Distances

The following table shows cable media types and maximum distances that support reliable transmission in accordance with international standards.

Table 6. Media Types and Maximum Distances

Standard	Media Type	Mhz•Km Rating	Maximum Distance (Meters)
1000BASE-SX (850 nm optical window)	50/125 µm multimode fiber	400	500
	50/125 µm multimode fiber	500	550
	62.5/125 µm multimode fiber	160	220
	62.5/125 µm multimode fiber	200	275
1000BASE-LX (1300 nm optical window)	50/125 µm multimode fiber	400	550
	50/125 µm multimode fiber	500	550
	62.5/125 µm multimode fiber	500	550
	9/125 µm single-mode fiber	–	10,000
1000BASE-LX70 (1550 nm optical window)	9/125 µm single-mode fiber	–	70,000
1000BASE-T	Category 5 and higher UTP cable	–	100
100BASE-TX	Category 5 and higher UTP cable	–	100
10BASE-T	Category 3 and higher UTP cable	–	100

RJ-45 Connector Jackets

Use RJ-45 cable with connector jackets that are flush with the connector or that have connectors with a no-snag feature.

Using cable with jackets that are wider than the connectors can cause:

- Connectors that are not properly aligned with the port.
- Crowded cable installation, which can cause connectors to pop out of the port.

The following figure shows examples of connector jacket types that are not recommended, as well as those that are recommended.

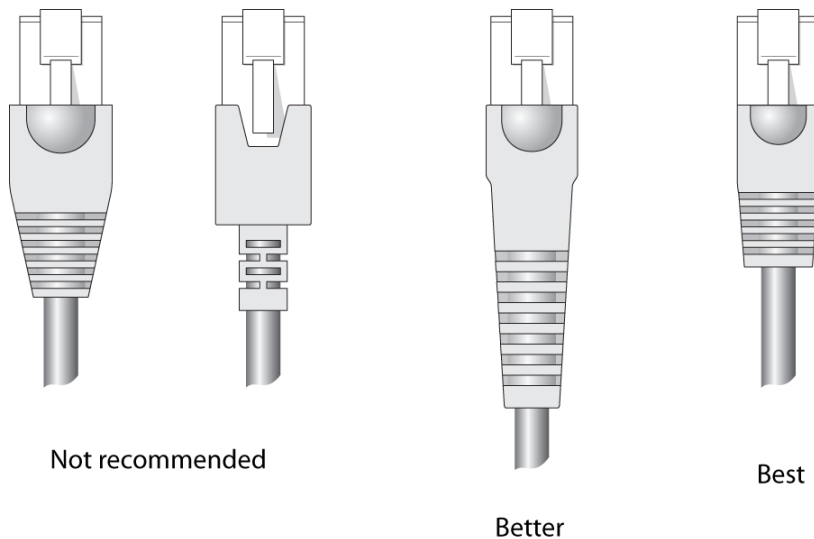

Figure 13. RJ-45 connector jacket types

Installing Cable

Consider the following recommendations when you connect cable to your network equipment:

- Examine cable for cuts, bends, and nicks.
- Support cable using a cable manager that is mounted above connectors to avoid unnecessary weight on the cable bundles.
- Use cable managers to route cable bundles to the left and right of the network equipment to maximize accessibility to the connectors.
- Provide enough slack, approximately 2 to 3 inches (5.08 to 7.62 cm), to provide proper strain relief as shown in [Figure 14, Correctly installed and bundled cable](#).
- Bundle cable using velcro straps to avoid injuring cables.
- If you build your own cable, be sure that cable is properly crimped.
- When installing a patch panel using twisted pair wiring, untwist no more than 1 inch (2.54 cm) of the cable to avoid radio frequency (RF) interference.
- Discharge the RJ-45 Ethernet cable before plugging it into a port on the switch.
- Use plenum-rated cable when it is necessary for safety and fire rating requirements. Consult your local building codes to determine when it is appropriate to use plenum-rated cable, or refer to IEC standard 850.
- Keep all ports and connectors free of dust.

**CAUTION:**

Unshielded twisted pair (UTP) cable can build up ESD charges when being pulled into a new installation. Before connecting any category 5 UTP cable to the switch, discharge ESD from the cable by plugging the RJ-45 connector into a LAN Static Discharge device or use an equivalent method.

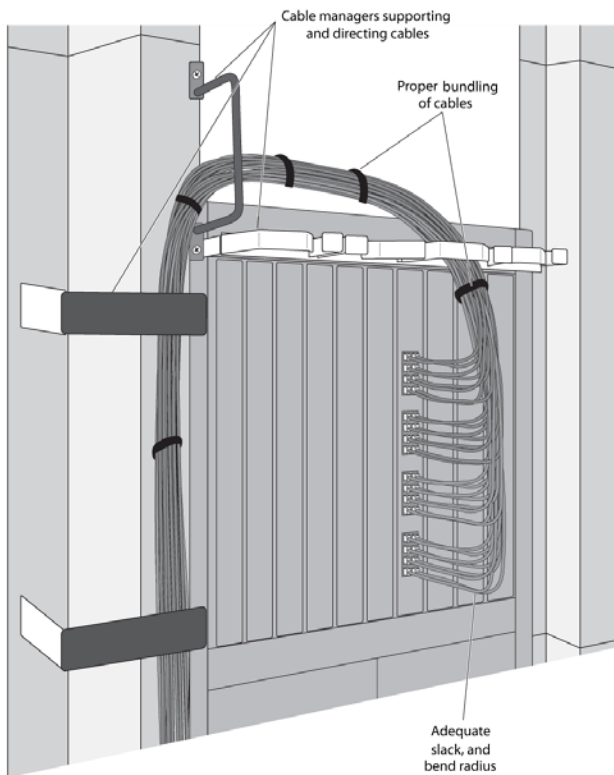

Figure 14. Correctly installed and bundled cable

Fiber Optic Cable

Fiber optic cable needs to be handled carefully during installation. Every cable has a minimum bend radius, for example, and fibers will be damaged if the cables are bent too sharply. It is also important not to stretch the cable during installation. We recommend that the bend radius for fiber optic cable equal 2 inches (5.08 cm) minimum for each 90 degree turn as shown in [Figure 15, Bend radius for fiber optic cable](#) on page 38.

Note: Kinks and sharp bends can destroy or impair the cable's ability to convey light pulses accurately from one end of the cable to the other. Use care in dressing the optical fiber cables: provide satisfactory strain relief to support the cable and maintain an adequate bend radius at all cable turns, particularly where the cable connects to the I/O module.

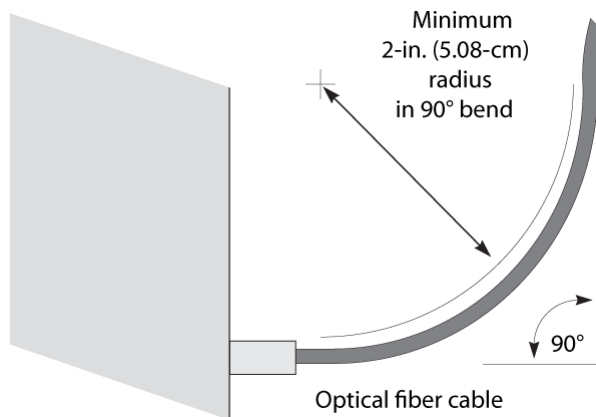

Figure 15. Bend radius for fiber optic cable

Radio Frequency Interference

If you use UTP cabling in an installation, take precautions to avoid RF interference. RF interference can cause degradation of signal quality, and, in an Ethernet network environment, can cause excessive collisions, loss of link status, or other physical layer problems that can lead to poor performance or loss of communication.

To prevent RF interference, avoid the following situations:

- Attaching UTP cable to AC power cables
- Routing UTP cable near antennas, such as an amateur radio antenna
- Routing UTP cable near equipment that could exhibit RF interference, such as ARC welding equipment
- Routing UTP cable near electrical motors that contain coils
- Routing UTP cable near air conditioner units
- Routing UTP cable near electrical transformers

In areas or applications where these situations cannot be avoided, use fiber optic cabling or shielded twisted pair cabling (STP).

Power Requirements

This section describes power requirements, including:

- [PoE Devices](#) on page 39
- [Power Supply Requirements](#) on page 39
- [AC Power Cord Requirements](#) on page 40
- [Uninterruptible Power Supply Requirements](#) on page 40

PoE Devices

When connecting power over Ethernet (PoE) devices to a PoE switch, all connections between the PoE device and the switch have to remain within the same building and you need to use a low-voltage power distribution system per IEEE 802.3af.

Power Supply Requirements

Follow these recommendations when you plan power supply connections for your equipment:

- Place the equipment in an area that accommodates the power consumption and component heat dissipation specifications.
- Be sure that your power supply meets the site DC power or AC power requirements of the network equipment.
- When you connect power to installed equipment, do not make this connection through an extension cord or power strip.
- If your switch includes more than one power supply, connect each power supply to different, independent power sources.

If a power source fails, it will affect only the power supply to which it is connected. If all switch power supplies are connected to a single power source, the entire switch is vulnerable to a power source failure.

- In regions that are susceptible to electrical storms, NETGEAR recommends that you plug your system into a surge suppressor.

For power specifications of the power supplies, see [Appendix B, Technical Specifications](#).



WARNING!

The chassis does not have a switch for turning power to the unit on and off. For systems using an AC power supply, power to the chassis is disconnected by removing the wall plug from the electrical outlet.

AC Power Cord Requirements

Should you use your own, make sure that the power cord you use is certified for the country of end use and suitable for the device. Check your local electrical codes and regulatory agencies for power cable requirements.

The power cord has to meet the requirements listed in [Selecting Power Supply Cords](#) on page 109.

Note: When using multiple power supplies, make sure that each AC power supply attaches to an independent power source.

Uninterruptible Power Supply Requirements

An uninterruptible power supply (UPS) is a device that sits between a power supply (such as a wall outlet) and a device (such as a switch) to prevent outages, sags, surges, and bad harmonics from adversely affecting the performance of the device.

A UPS traditionally can perform the following functions:

- Absorb relatively small power surges.
- Smooth out noisy power sources.
- Continue to provide power to equipment during line sags.
- Provide power for some time after a blackout has occurred.

In addition, some UPS or UPS plus software combinations provide the following functions:

- Automatically shut down equipment during long power outages.
- Monitor and log power supply status.
- Display the voltage (current draw) of the equipment.
- Restart equipment after a long power outage.
- Display the voltage currently on the line.
- Provide alarms on certain error conditions.
- Provide short circuit protection.

Selecting a UPS

To determine UPS requirements for your switch, answer these questions:

- What are the amperage requirements?
- What is the longest potential time period that the UPS would be required to supply backup power?
- Where will the UPS be installed?
- What is the maximum transition time that your installation will allow?

Note: NETGEAR recommends that you use a UPS that provides online protection.

Calculating Volt-Amperage Requirements

To determine the minimum volt-amperage requirements for your UPS:

1. Locate the voltage and amperage requirements for each piece of equipment. These numbers are usually located on a sticker on the back or bottom of your equipment.
2. Multiply the numbers together to get Volt-Amps (VA):

$$\text{VA} = \text{Volts} \times \text{Amperes}$$

3. Add together the VA from all the pieces of equipment to find the total VA requirement.

To determine the minimum volt-amperage requirements for your UPS, we recommend that you add 30% to the total.

UPS Transition Time

Transition time is the time that is necessary for the UPS to transfer from utility power to full-load battery power. A transition time of less than 20 milliseconds is required for optimum performance.

Applicable Industry Standards

For more information, see the following ANSI/TIA/EIA standards:

- ANSI/TIA/EIA-568-A—discusses the six subsystems of a structured cabling system.
- ANSI/TIA/EIA-569-A—discusses design considerations.
- ANSI/TIA/EIA-606—discusses cabling system administration.
- ANSI/TIA/EIA-607—discusses commercial building grounding and bonding requirements.

You can access these standards at:

<http://www.ansi.org>

or

<http://www.tiaonline.org>

5 Install an 8800 Series Chassis

5

This chapter includes the following sections:

- *Unpack the XCM8806 Chassis* on page 43
- *Unpack the XCM8810 Chassis* on page 45
- *Pre-installation Requirements* on page 48
- *Rack Mount the 8800 Series Chassis* on page 48
- *Ground the 8800 Series Chassis* on page 50

This chapter describes how to install the following chassis models:

- XCM8806 chassis
- XCM8810 chassis

The 8800 series chassis fits into a standard 19-inch (48.26 cm) rack.

Note: Read the information in this chapter thoroughly before you attempt to install the 8800 series switch.



CAUTION:

Correct lifting of the 8800 series chassis requires two people.

Before you lift a 8800 series chassis, make sure the chassis is empty to prevent unnecessary weight. This will also prevent damage to the system components due to possible system chassis flex when lifting.

Unpack the XCM8806 Chassis



CAUTION:

The XCM8806 chassis weighs almost 65 pounds. Proper lifting and moving of the chassis requires two people.

To unpack the XCM8806 chassis:

1. Open the top flaps and remove the accessories and documentation pack from the shipping carton. Lift out the packing foam.

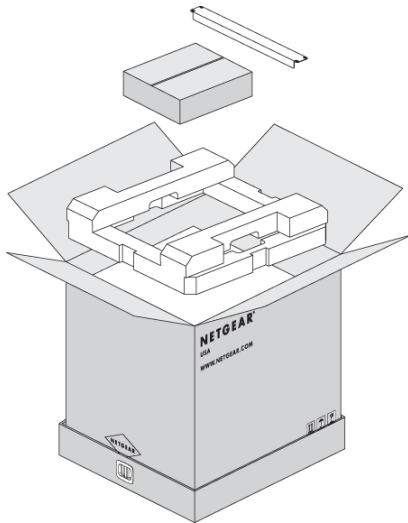

Figure 16. Removing accessories from the XCM8806 Chassis shipping carton

2. Remove the plastic clip locks at the bottom of the carton.
 - a. In each clip lock, squeeze the prongs together firmly.
 - b. Pull the clip lock outward from the carton.

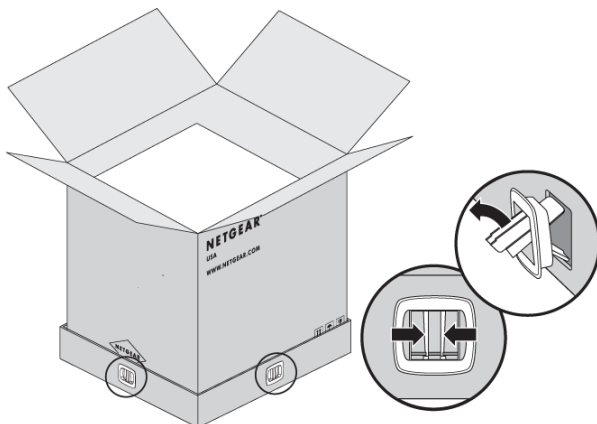

Figure 17. Clip locks on the XCM8806 Chassis shipping carton

3. Slide the shipping carton up over the XCM8806 chassis.

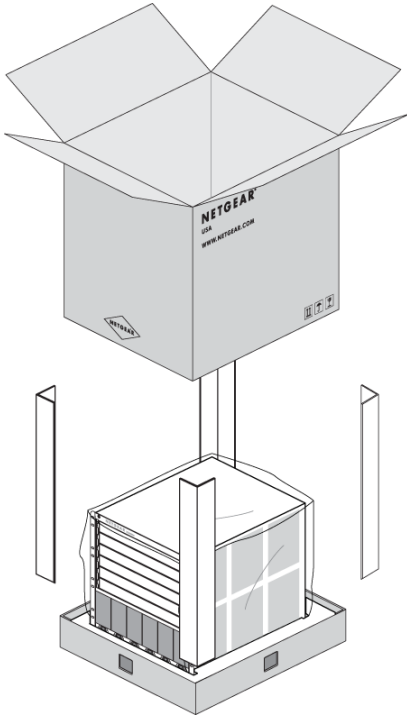

Figure 18. Removing the carton from the XCM8806 Chassis

4. Unwrap the chassis.
5. At each side of the chassis, place one hand in an empty power supply bay and the other hand in the recessed hand-hold on the back panel of the chassis. Carefully lift the XCM8806 chassis off the foam cushion and onto the floor.

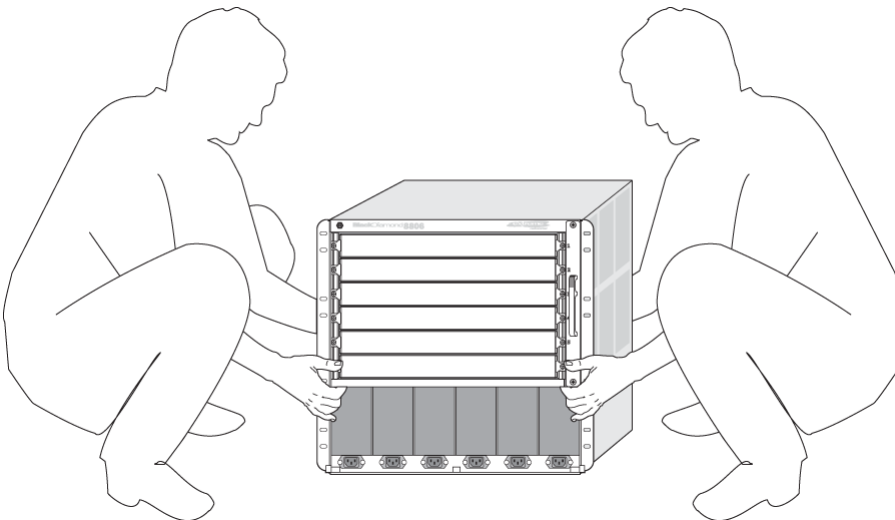

Figure 19. Correct method for lifting the XCM8806 Chassis



CAUTION:

Do not use the fan tray handle to lift or maneuver the XCM8806 chassis. This handle is not designed to support the weight of the chassis.

Verify that the following items are included in the shipping carton:

- XCM8806 chassis with four installed blank front panels
- Power cord retainer
- 19-inch support bracket
- Documentation pack with ESD-preventive wrist strap

Note: Save all packaging, clip locks, and box pieces for future use in the event that the XCM8806 chassis has to be moved to another location or returned.

Unpack the XCM8810 Chassis



CAUTION:

The XCM8810 chassis weighs almost 80 pounds. Proper lifting and moving of the chassis requires two people.

To unpack the chassis:

1. Remove the plastic straps from around the shipping container.

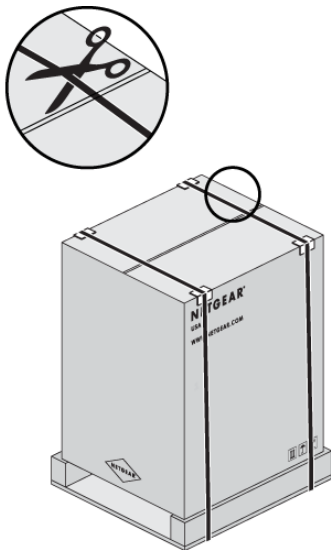

Figure 20. Removing the plastic straps

2. Open the flaps and remove the contents from the upper shipping carton.

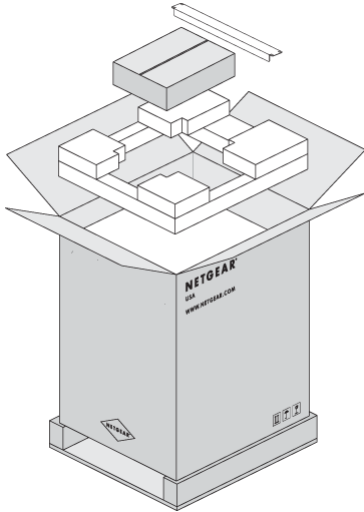

Figure 21. Removing contents from the upper shipping carton

3. Lift the XCM8810 shipping carton up and off the chassis.

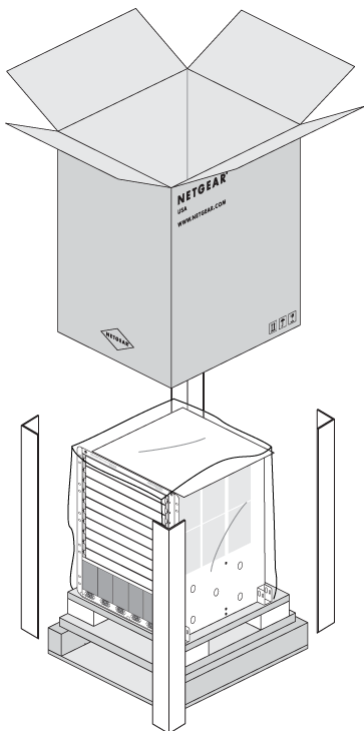

Figure 22. Unpacking the XCM8810 Chassis

4. Remove all four restraining bolts that hold the XCM8810 chassis to the shipping brackets on the shipping pallet.

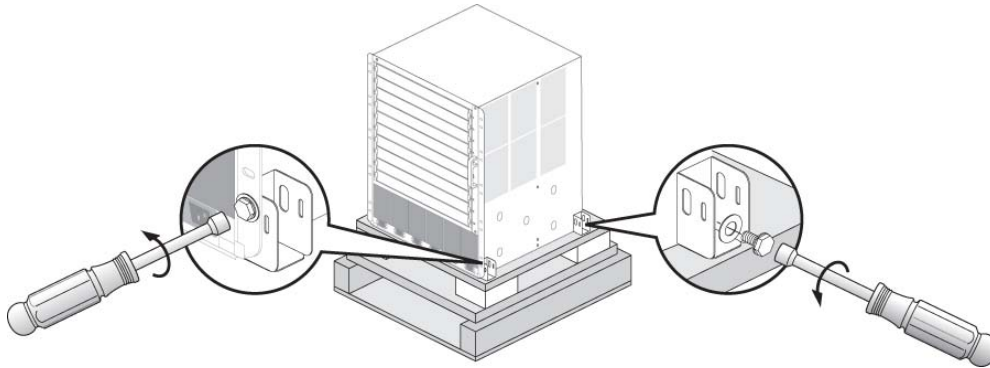

Figure 23. Removing the restraining bolts

5. At each side of the chassis, place one hand in an empty power supply bay and the other hand in the recessed hand-hold on the back panel of the XCM8810 chassis (see [Figure 24](#), *Correct method for lifting the XCM8810 Chassis*).



CAUTION:

Do not use the fan tray handle to lift or maneuver the XCM8810 chassis. This handle is not designed to support the weight of the chassis.

6. Carefully lift the chassis off the shipping pallet and onto the floor as shown in the following figure.

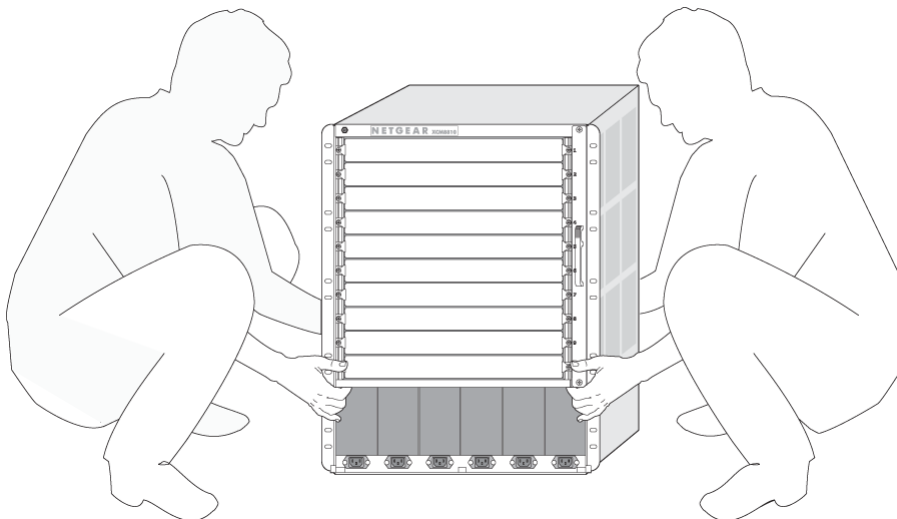

Figure 24. Correct method for lifting the XCM8810 Chassis

Verify that the following items are included in the shipping carton:

- XCM8810 chassis with eight installed blank front panels
- Power cord retainer
- 19-inch support bracket
- Documentation pack with ESD-preventive wrist strap

Note: Save all packaging, clip locks, and box pieces for future use in the event that the XCM8810 chassis needs to be moved to another location or returned.

Pre-installation Requirements

The following tools, equipment, and resources are required for installing the 8800 series chassis:

- ESD-preventive wrist strap (provided)
- 19-inch support bracket (provided)
- Rack-mount screws appropriate for your organization's rack system, as follows:
 - 4 screws to attach the support bracket
 - 12 screws to secure the chassis in the rack

The screw size will vary based on your organization's rack system; screws are not provided.

- Screwdriver appropriate for the rack-mounting screws you will use

The screwdriver size depends on the requirements of your organization's rack system.

Rack Mount the 8800 Series Chassis

To mount the 8800 series chassis in a rack:

1. Locate the 19-inch support bracket that is shipped with the 8800 series chassis.
2. Identify the rack location where the chassis will be installed.
3. Using four rack mounting screws, attach the support bracket to the rack immediately below the chassis location. You need to provide the screws for attaching the support bracket.

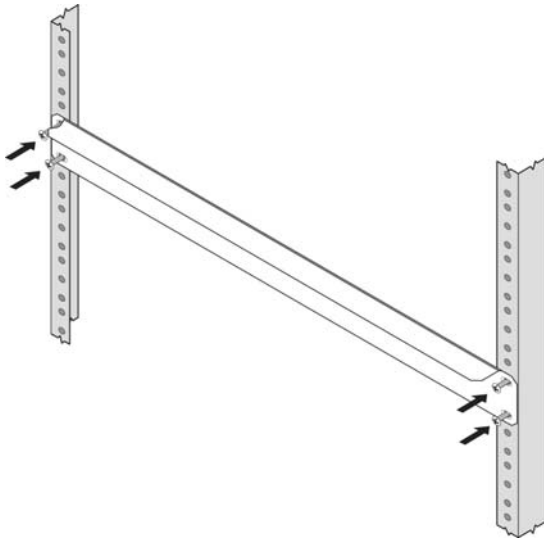

Figure 25. Attaching the support bracket to the rack

4. Lift the back of the empty 8800 series chassis onto the support bracket.
5. Slowly guide the chassis into the rack until the mounting brackets are flush against the rack uprights.
6. Secure the chassis to the rack using eight rack mounting screws. (Screws are not provided.) Be sure that the screws are secure. Refer to [Figure 26](#) and [Figure 27](#) for the screw locations.

Note: [Figure 26](#) and [Figure 27](#) show a standard rack mount. For mid-mount installation, use the same mounting locations shown in the figure, but insert the screws through the designated slot locations of the mid-mount brackets.

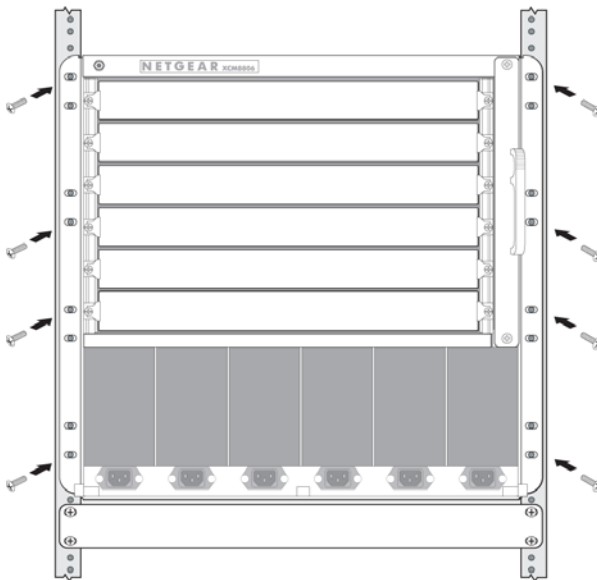

Figure 26. Securing the XCM8806 Chassis to a rack

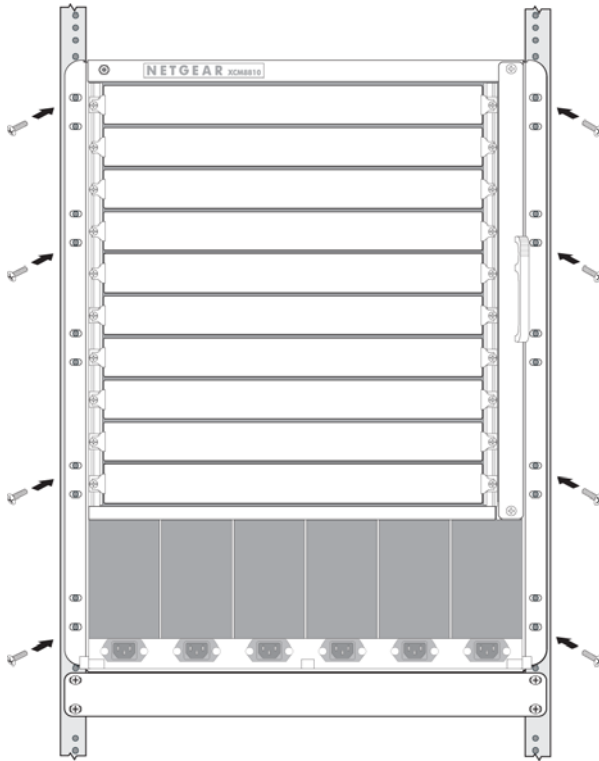

Figure 27. Securing the XCM8810 Chassis to a rack

7. Remove the support bracket from the rack after the chassis is secured. Save the bracket for future use if you remove the chassis from the rack.

Ground the 8800 Series Chassis

Although grounding the 8800 series chassis is optional, it is recommended. A grounding point with integrated pem-nuts is provided on the back of the chassis.

You need the following materials to ground the chassis:

- Two 10-24 screws
- One copper, standard barrel 2-hole compression grounding lug, type LDC, equivalent to Panduit part number LCD4-14A-L or Thomas & Betts part number: LCN4-14
- Appropriate grounding wire for your system, based on the available input current for the power supply:
 - For AC systems using a 20A breaker per PSU (SSI AC), the chassis ground can be as small as 14 AWG.
 - For DC systems using a 40A breaker per PSU (SSI DC), the chassis ground can be as small as 10 AWG.

To ground the chassis:

1. Locate the grounding point on the back of the chassis (**Figure 28** and **Figure 29**).

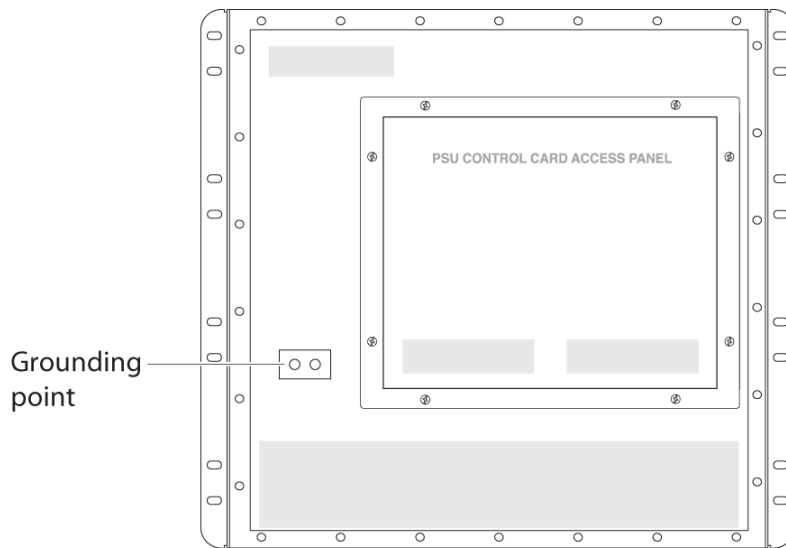

Figure 28. Back of XCM8806 Chassis

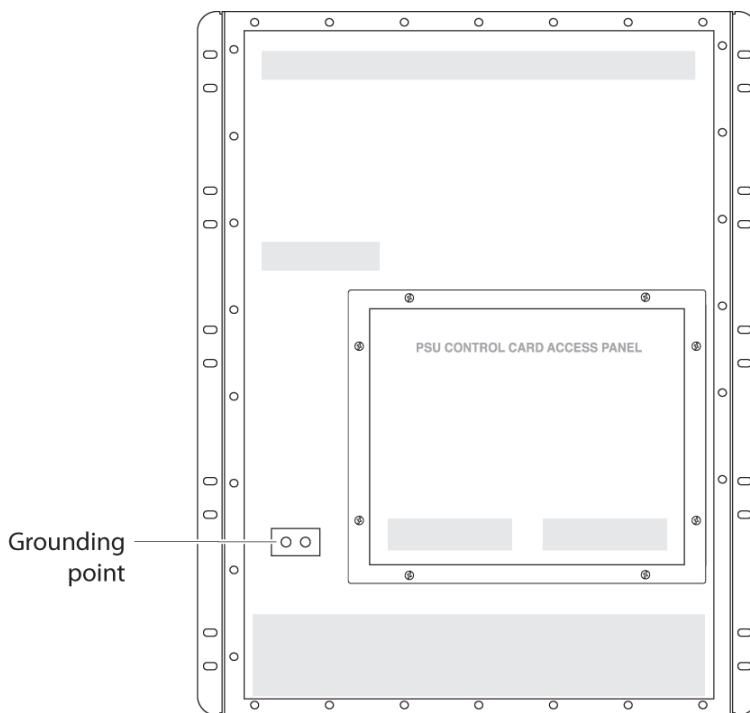

Figure 29. Back of XCM8810 Chassis

2. Strip 0.5-inch (1.2-cm) of insulation from the stranded copper wire cable.
3. Insert the stripped wire into the cable lug.



CAUTION:

Be sure that no copper is visible between the lug and the cable insulation.

4. Crimp the lug onto the cable according to the manufacturer's specifications.
5. Insert the screws through the lug and into the grounding point on the back of the chassis.
6. Connect the other end of the wire to a known reliable earth ground point at your site.

6 Install Power Supply Units in the Switches

6

This chapter includes the following topics:

- *Safety* on page 54
- *Power Supply Cords for AC Power Supplies* on page 55
- *Install a PSU* on page 56

The chapter describes how to install and remove each power supply model used with the 8800 series switches.

Safety

Only trained service personnel should perform service to NETGEAR switches and their components. Trained service personnel have read all related installation manuals, have the technical training and experience necessary to be aware of the hazards to which they are exposed in performing a task, and are aware of measures to minimize the danger to themselves or other persons.

Before installing a NETGEAR PSU into your network:

- Read the latest installation and safety information provided in this chapter and in [Appendix A, Safety Information](#)
- See [Appendix A, Safety Information](#) for additional information regarding regulatory compliance certifications.



CAUTION:

Building codes vary worldwide; therefore, NETGEAR strongly recommends that you consult an electrical contractor to ensure proper equipment grounding and power distribution for your specific installation.



WARNING!

Field operators must not attempt to open the PSU enclosure for any reason; the PSU does not contain user-serviceable parts. In the event of failure, return the defective PSU for repair or replacement.



WARNING!





The PSUs do not have switches for turning the unit on and off. Remove the wall plug from the electrical outlet to disconnect the power to a PSU. Make sure that this connection is easily accessible.

When the PSU is outside the chassis (not installed), do not plug the PSU into an electrical outlet. Plugging an uninstalled PSU into an electrical outlet exposes you to a hazardous energy and is a potential fire hazard.

Power Supply Cords for AC Power Supplies

The power supply cords provided in the package with the PSU are shown in the following table.

Table 7. Power Supply Cords

Model	Product Name	Region
 10041	Power cord, 10A, NEMA 5-15P, IEC320-C13, Right Angle	North America
 10042	Power cord, 12A, JISC8303, IEC320-C13, Right Angle	Japan
 10043	Power cord, 10A, CEE 7/7, IEC320-C13, Right Angle	Europe
 10044	Power cord, 10A, BS1363, IEC320-C13, Right Angle	Great Britain
 10046	Power cord, 10A, NAS3112, IEC320-C13, Right Angle	Australia

Each power cord is enclosed in a plastic wrapper with its model number and product name on it. Locate the correct cord based on your region. The PSUs used with the 8800 series switches can use either 110 V AC or 220 V AC power supply cords. The following table shows the maximum DC power output allowed by these power cords when used with the 700W AC power supply.

Should you purchase your own, the power cord must meet the requirements listed in [Selecting Power Supply Cords](#) on page 109.

Table 8. AC Power Supply Cords for the 700/1200 W AC Power Supply

Cord Type	Maximum DC Output Power
110 V AC	700 W
220 V AC	1200 W



WARNING!

Be sure that the source outlet is properly grounded before plugging the AC power cord into the PSU.

Install a PSU

The power supply bay in the 8800 series switch can accommodate up to six hot-swappable PSUs.



WARNING!

Field operators must not attempt to open the PSU enclosure for any reason; the PSU does not contain user-serviceable parts. In the event of failure, return the defective PSU for repair or replacement.



CAUTION:

To ensure proper cooling of the PSU, do not block the front vents of the PSU or the rear vents of the switch.

Required Tools and Equipment

You need the following tools and equipment to install or remove a PSU:

- ESD-preventive wrist strap
- Power supply cord (110 V AC, 220 V AC, or applicable to country of use)
- Thermal protective gloves (required for removal)

Install the 100-240VAC PSU XCM88PS1



CAUTION:

Make sure that the PSU circuit is not overloaded. Use proper over-current protection, such as a circuit-breaker, to prevent over-current conditions.

To install the PSU:

1. Attach an ESD-preventive wrist strap to your bare wrist and connect the metal end to the ground receptacle on the top-left corner of the switch front panel.
2. Verify that the PSU is right side up and the locking handle is open.

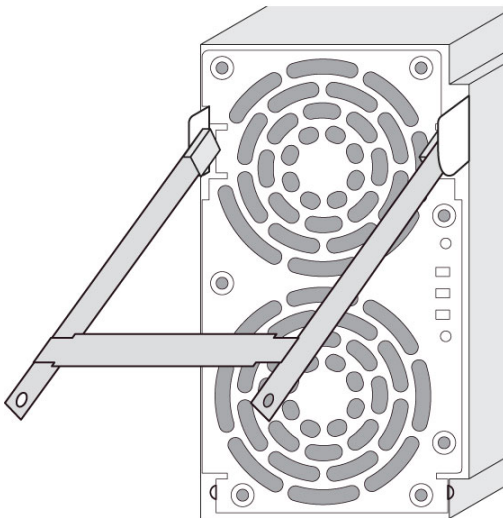

Figure 30. PSU with locking handle open

3. Carefully slide the PSU all the way into the power supply bay (see [Figure 31, Inserting a PSU into the power supply bay](#)).



CAUTION:

Do not slam the PSU into the system switch backplane. Use the locking handle to secure the PSU in the power supply bay.

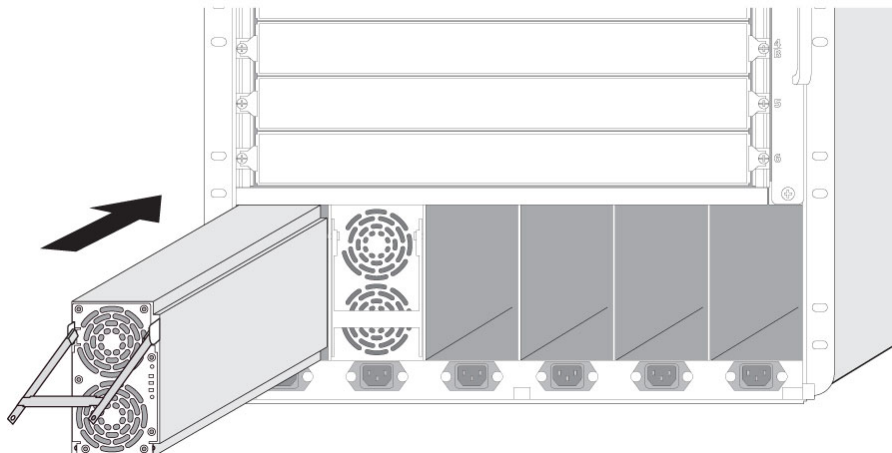

Figure 31. Inserting a PSU into the power supply bay

4. Secure the PSU in the power supply bay by pushing down on the locking handle until it clicks into place.
5. If you are replacing a power supply, you do not need to unplug the AC power cord. For a newly installed power supply, connect the AC power supply cord:
 - a. If necessary, remove the power cord retainer as described in [Chapter 9, AC Power Cord Retainers](#)
 - b. Connect the new AC power cord to the AC input on the front of the switch and to the wall outlet on the other end. Then re-install the power cord retainer.
 - c. Re-install the power cord retainer as described in [Chapter 9, AC Power Cord Retainers](#)

To install additional PSUs, repeat [step 2](#) through [step 5](#).

Note: Leave the ESD strap permanently connected to the switch, so that the strap is always available when you need to handle ESD-sensitive components.

Remove or Replace a PSU



CAUTION:

The PSU may be hot to the touch; use thermal protective gloves when handling the PSU during removal.

To remove or replace a PSU:

1. Attach an ESD-preventive wrist strap to your bare wrist and connect the metal end to the ground receptacle on the top-left corner of the switch front panel (if not already attached).
2. For the AC power cord:
 - If you are replacing only the power supply and you will use the existing AC power cord for the new PSU, you do not need to unplug the AC power cord.
 - If you are removing and replacing an AC power cord:
 - a. Remove the power cord retainer as described in *Disconnect an XCM8810 Power Cord* on page 84 or *Remove the XCM8806 Power Cord Retainer* on page 87.
 - b. Completely disconnect and remove the old power cord.
 - c. Connect the new AC power cord to the AC input on the front of the switch and then connect the opposite end of the AC power cord to the wall outlet.
 - d. After the cord is connected, re-install the power cord retainer.
3. Lift the handle on the PSU.
4. Pull the handle of the PSU to disconnect the PSU from the power connector at the back of the power supply bay. Slide the PSU partway out of the bay.
5. Wearing thermal protective gloves, place both hands underneath the PSU to support the weight as it is pulled out from the switch.
6. To install a replacement PSU, follow the steps under *Install the 100-240VAC PSU XCM88PS1* on page 57.

Note: Leave the ESD strap permanently connected to the switch, so that the strap is always available when you need to handle ESD-sensitive components.

7 Install Modules and Establish Initial Management Access

7

The chapter describes how to install the Supervisory modules and I/O modules in the 8800 series switches and how to set up initial management access for the switch. All module types are hot-swappable.

The chapter includes the following sections:

- *Module Slot Assignments* on page 61
- *Distinguishing a Supervisory Module from an I/O Module* on page 61
- *Install an XCM8000 Series Module* on page 62
- *Connect Network Interface Cables* on page 65
- *Install a Backup Supervisory Module* on page 65
- *Verify the Module Installation* on page 65
- *Remove an XCM8000 Series Module* on page 66
- *Blank Front Panels* on page 68
- *Install or Remove an External Compact Flash Memory Card* on page 71
- *Initial Management Access* on page 72

Read the information in this chapter thoroughly before you attempt to install or remove an 8800 series Supervisory module or I/O module.

Module Slot Assignments

The specific slot locations for I/O modules and Supervisory modules in the chassis are as follows:

- XCM8810 switch
 - Slots 1, 2, 3, 4, 7, 8, 9, and 10 can accommodate only I/O modules.
 - Slot 5/A can accommodate only an Supervisory module.
 - Slot 6/B can accommodate an Supervisory module or I/O module
- XCM8806 switch
 - Slots 1, 2, 5, and 6 can accommodate only I/O modules.
 - Slot 3/A can accommodate only an Supervisory module.
 - Slot 4/B can accommodate an Supervisory module or I/O module

The following slots can only operate an Supervisory module:

- *Slot 5/A in the XCM8810 chassis*
- *Slot 3/A in the XCM8806 chassis*

Supervisory modules reside in different slots depending on which switch you operate:

- If you are using only one Supervisory module in the XCM8806 switch, install that Supervisory module in slot 3. If you add a second Supervisory module to increase reliability and throughput, install the second Supervisory module in slot 4.
- If you are using only one Supervisory module in the XCM8810 switch, install that Supervisory module in slot 5. If you add a second Supervisory module to increase reliability and throughput, install the second Supervisory module in slot 6.

Distinguishing a Supervisory Module from an I/O Module

One quick way to distinguish an 8800 series Supervisory module from an I/O module is by the color of the release latch on each injector/ejector handle. Orange injector/ejector release

latches indicate that the module is a Supervisory module, and green injector/ejector release latches indicate that the module is a I/O module.

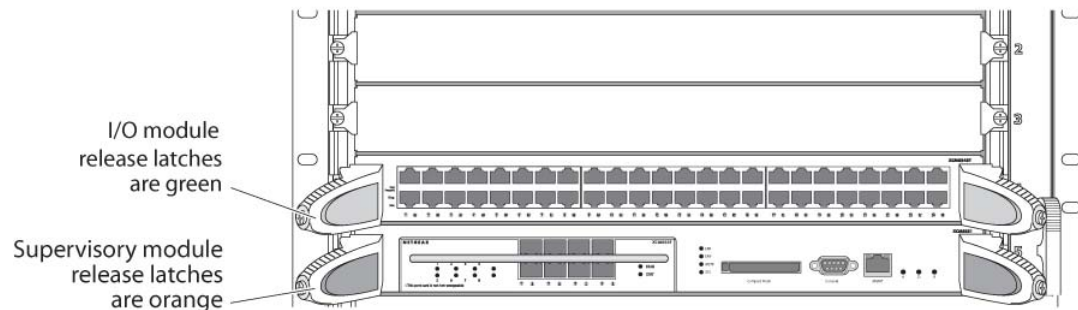

Figure 32. Colors on Injector/ejector release latches

Install an XCM8000 Series Module

You need the following tools and equipment to install an XCM8000 series I/O module or Supervisory module:

- ESD-preventive wrist strap
- #2 Phillips screwdriver
- Appropriate type of cable for any ports on the module

When you handle modules, optical devices, or other modular accessories, use an ESD-preventive wrist strap to reduce the risk of electronic damage to the equipment. Transport PC boards only in electrostatic packaging. Always place PC boards on a grounded surface before working on them.

To install a module in a 8800 series switch:

1. Attach the ESD-preventive wrist strap to your bare wrist and connect the metal end to the ground receptacle at the top left corner of the chassis.
2. Select a slot for the module. (See [Module Slot Assignments](#) on page 61.)



CAUTION:

Supervisory modules and I/O modules only fit properly into their designated slots. Forceful insertion into the wrong slot type can damage the module.

3. Remove a blank front panel from the chassis slot, if applicable.

Note: Any unoccupied module slot in the chassis should have a blank faceplate installed to ensure satisfactory protection from EMI and to maintain adequate airflow through the chassis.

4. Remove the module from the antistatic packaging as follows:
 - a. Place the antistatic bag containing the module on a flat ESD-protective surface that is clear of any debris.
 - b. Break the quality seal, the ESD warning seal, and the Read Installation Note seal.
 - c. Open the antistatic bag and firmly grasp the rail of the module.
 - d. Hold the rail of the module as you pull the antistatic bag off the module.

Note: By holding the rail of the module and pulling the ESD bag off the module, you prevent damage to the module that might be caused by sliding the module on the ESD surface.

Store the module packaging for future use.



CAUTION:

To prevent ESD damage, hold the module by the metal rail and front panel only. Never touch the components on the PCB or the pins on any of the connectors.

5. Verify that the module injector/ejector handles are open.

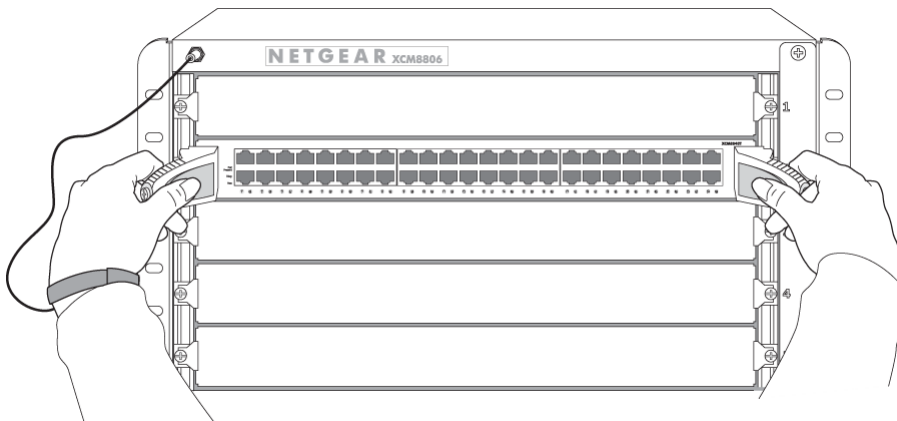

Figure 33. Injector/ejector handles in an open position

6. Keep the injector/ejector handles in the open position as you slide the module into the chassis slot.



CAUTION:

Do not slide the module into the open chassis slot if the injector/ejector handles are in the latched position.

- Use both hands to latch the injector/ejector handles, by simultaneously pushing both handles toward the center of the module, as shown in the following figure.

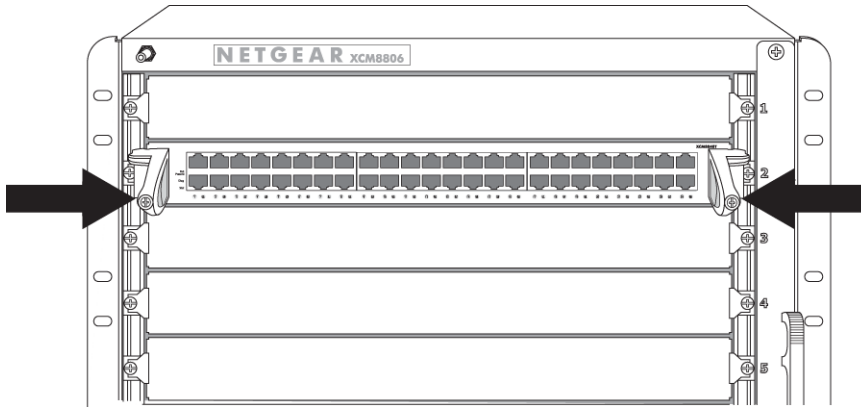

Figure 34. Injector/ejector handles in the latched position

- Using a #2 Phillips screwdriver, turn the screw on each injector/ejector handle clockwise and *completely* down to lock the module into place (**Figure 35**). When the screw is fully tightened, the yellow band around the captive screw is completely hidden.



CAUTION:

Be careful to avoid over-torquing and stripping the screw heads.

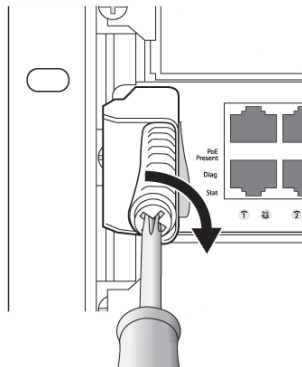

Figure 35. Locking the module into place

- Store the module packaging for future use.

Leave the ESD-preventive wrist strap permanently connected to the chassis so that the strap is always available when you need to handle ESD-sensitive components.

Connect Network Interface Cables

Use the appropriate type of cable to connect the ports of your switch to another switch or router.

Working carefully, one port at a time:

1. Verify that you have identified the correct cable for the port.
2. Use an alcohol wipe or other appropriate cleaning agent to clean the cable connectors; make sure they are free of dust, oil, and other contaminants.
3. If you are using optical fiber cable, align the transmit (Tx) and receive (Rx) connectors with the correct corresponding connectors on the switch or the I/O module.
4. Press the cable connectors into their mating connectors on the switch or I/O module until the cable connector is firmly seated.
5. Repeat steps 1 through 4 for the remaining cables on this or other switches or I/O modules.
6. Dress and secure the cable bundle to provide appropriate strain relief and protection against bends and kinks.

Install a Backup Supervisory Module

If you install a backup Supervisory module, use the `synchronize` command to replicate all saved images and configurations from the primary Supervisory module to the backup Supervisory module.

You are not prompted to synchronize the images and the configurations from the primary to the backup. If not synchronized, the backup uses its image and the primary configuration. This image/configuration mismatch will likely cause the switch to operate differently after failover.



CAUTION:

Depending on the size and complexity of your network, you should install and configure a backup Supervisory module when network disruption will be minimal. You may need to reboot your switch after you use the `synchronize` command.

Verify the Module Installation

After you install a module, verify that it is working correctly by checking the LEDs on the front panel of the module. The following table shows normal LED operation for correctly installed Supervisory modules and I/O modules.

Use the command line interface (CLI) `show slot <slot number>` command to display slot-specific information about the newly installed module.

Table 9. Module LED Activity for Normal Operation

Supervisory Module		I/O Module	
SYS LED	Green blinking	STATUS LED	Green blinking
MSTR LED	Green: Primary Supervisory module Amber: Backup Supervisory module	DIAG	Off
ENV LED	Green	Port status (per port) LED	Green Amber blinking
Link/Activity LED	Green: Link is up. Amber: Packet activity is occurring.		

For more information about LED activity, see the module chapter for each switch series.

Displaying Slot Status Information

Assuming the module has no problems, the command `show slot <slot>` (where `<slot>` is the number of the slot where you installed the module) displays information about the module including: general information about the module (name, serial number, part number), the state of the module (power down, operational, mismatch between the slot configuration and the module in the slot), and the number of ports on the module.

For more information about slot status information, see the *NETGEAR 8800 Series Chassis Switch User Manual* and the *NETGEAR 8800 Series Chassis Switch CLI Manual*.

Remove an XCM8000 Series Module

This section describes how to remove modules from a 8800 series switch. Modules are hot-swappable. You do not need to power the system off to remove a module.

You need the following tools and equipment to remove an 8800 series module:

- ESD-preventive wrist strap
- #2 Phillips screwdriver
- Replacement module or blank faceplate if you are not replacing the module

To remove a module:

1. Attach the ESD-preventive wrist strap to your bare wrist. If it is not already connected, connect the metal end to the ground receptacle at the top left corner of the chassis.
2. To unlock the module, turn each captive screw counter-clockwise (**Figure 36**). Verify that the yellow band around the captive screw head of each injector/ejector handle is completely visible (**Figure 36**). This position ensures that the module is unlocked.

**CAUTION:**

Be sure to turn each captive screw only 90 degrees or one-quarter turn counter-clockwise. Loosening the captive screws beyond 90 degrees will damage the injector/ejector handles on the module.

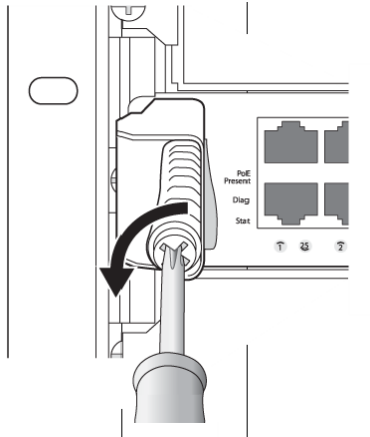

Figure 36. Unlocking a module

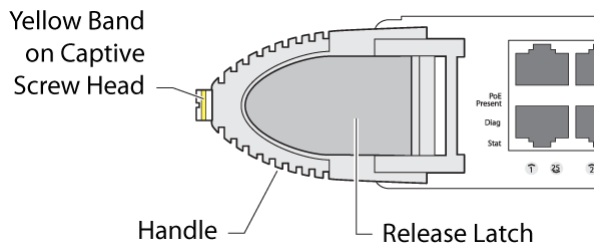

Figure 37. Indications that the module is unlocked

3. Squeeze the release latch on each injector/ejector handle and rotate both handles outward to disconnect the module from the chassis backplane (see [Figure 37](#)).

**CAUTION:**

To prevent ESD damage, hold the module by the metal panel edges only. Never touch the components on the PCB or the pins on any of the connectors.

4. Slide the module out of the chassis slot.
5. Immediately place the module into the anti-static bag to protect it from potential ESD damage. The bag will also prevent dust from collecting on the module connectors.
6. If you are not going to install a replacement module, install a blank front panel. To install a replacement module, follow the installation procedure.

Note: Leave the ESD-preventive wrist strap permanently connected to the chassis so that it is always available when you need to touch ESD-sensitive components.

Blank Front Panels

The switches are shipped with blank front panels installed over one or more chassis slots. You can remove or install a blank front panel at any time without disrupting network services. Complete the action of installing a blank front panel in a reasonable time-frame to avoid disruption to adequate airflow.



CAUTION:

All unoccupied slots in a 8800 series switch must have blank front panels correctly installed to ensure conformance to FCC requirements as well as to maintain adequate airflow through the switch.

You need the following tools and equipment to install or remove a blank front panel:

- ESD-preventive wrist strap
- #2 Phillips screwdriver

Install a Blank Front Panel

To install the blank front panel:

1. Attach the ESD-preventive wrist strap to your bare wrist and connect the metal end to the ground receptacle at the top left corner of the chassis.
2. Align the blank front panel over the open slot on the chassis (see [Figure 38](#)).

Verify that the EMI gasket is on the top of the panel and the stenciled part number is right side up.

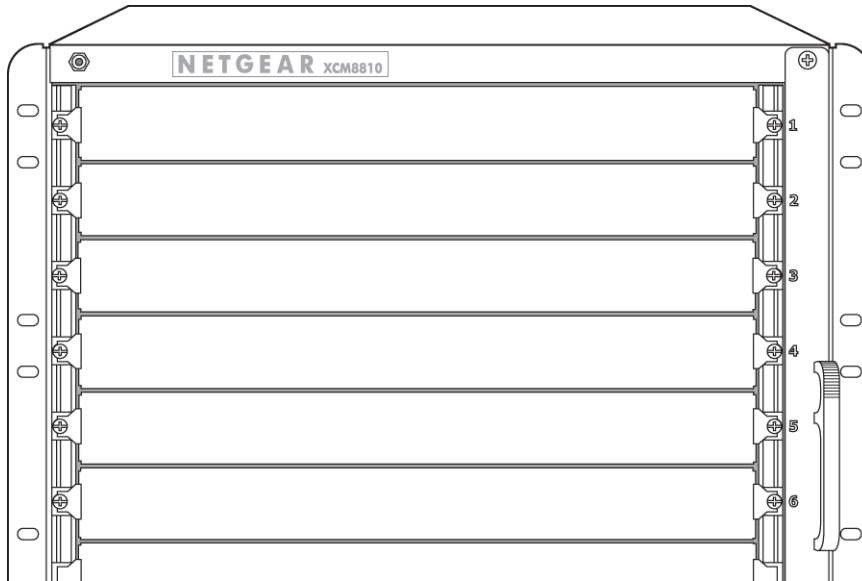

Figure 38. Blank front panels in an 8800 Series Chassis

3. Use a #2 Phillips screwdriver to tighten the captive screws at each end of the blank front panel.
 - Tighten the screws of each installed blank front panel before inserting additional modules or blank front panels. Otherwise, you might unseat modules or blank front panels that you have not secured.
 - Leave the ESD-preventive wrist strap permanently connected to the chassis so that it is always available when you need to touch ESD-sensitive components.

Remove a Blank Front Panel

To remove a blank front panel:

1. Attach the ESD-preventive wrist strap to your bare wrist and connect the metal end to the ground receptacle at the top left corner of the switch front panel.

- Loosen the captive screw at each end of the blank front panel, using a #2 Phillips screwdriver.

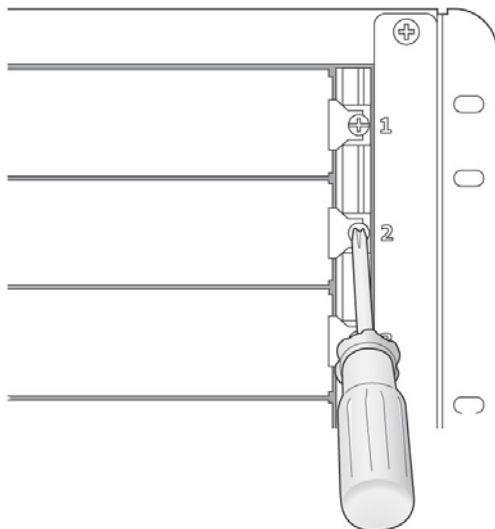

Figure 39. Captive screw on a blank front panel

- Remove the blank front panel from the front of the switch.

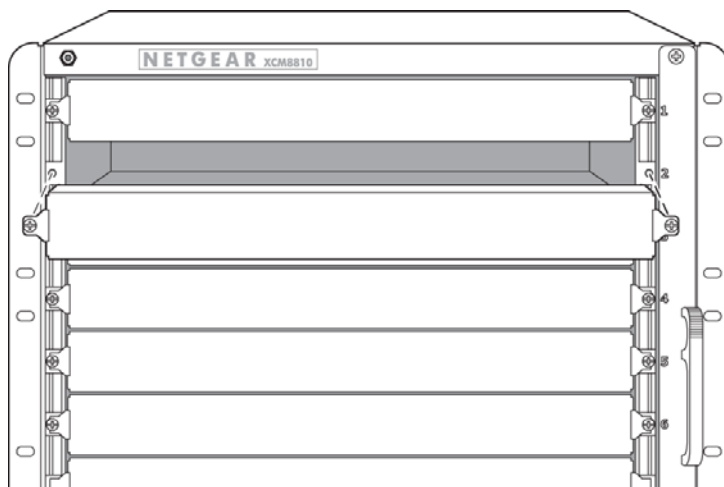

Figure 40. Removing a blank front panel from a 8800 series switch

- Install an I/O module or Supervisory module in the open slot as described in [Install an XCM8000 Series Module](#) on page 62.

Note: Leave the ESD-preventive wrist strap permanently connected to the switch, so that the strap is always available when you need to handle ESD-sensitive components.

Install or Remove an External Compact Flash Memory Card

You do not need to power off the system or remove the Supervisory module from the chassis to install or remove an external compact flash memory card.

You need an ESD-preventive wrist strap to install a compact flash memory card.

To install the memory card:

1. Attach the ESD-preventive wrist strap to your bare wrist and connect the metal end to the ground receptacle on the chassis front panel.
2. Locate the compact flash slot on the Supervisory module.

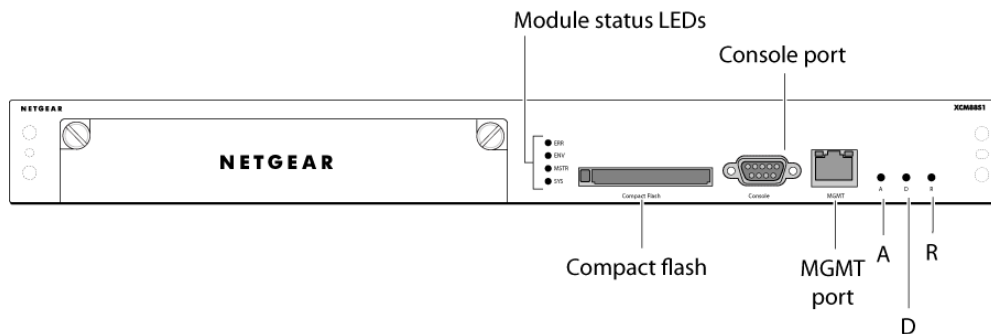

Figure 41. Compact flash slot location

3. Hold the memory card between your thumb and forefinger.
The side with the ridge faces toward the bottom of the chassis.
4. Slide the card into the compact flash slot until you feel resistance.; a portion of the card will protrude from the slot.
5. Carefully push the card until it is seated into the slot. The card should be fully inserted, or seated, inside the slot.
6. To verify that the card is fully seated, use the `show memorycard` command.

To remove the external compact flash memory card:

1. Use the `eject memorycard` command to ensure that you will not lose any data when you remove the card.

After you use the `eject memorycard` command, you can physically remove the card from the external compact flash slot on the Supervisory module. For more information about the `eject memorycard` command, see the *NETGEAR 8800 Series Chassis Switch User Manual*.

2. Attach the ESD-preventive wrist strap to your wrist and connect the metal end of the strap to the ground receptacle on the chassis front panel.
3. Locate the black release pin just above the compact flash slot.

4. Press the release pin until the card releases from the slot.
The card releases to an intermediate position; the card remains partially inserted but is no longer seated in the slot.
5. Remove the card completely and place it in a safe location.

Initial Management Access

After your switch has completed all power on self-tests, it is operational. You can log in and configure an IP address for the default VLAN (named *default*).

Note: The management port on the Supervisory module is part of the management VLAN by default. Refer to *Management Ports* on page 8 for further details.

Connect Equipment to the Console Port

Connection to the console port is used for direct local management. The console port settings are:

- Baud rate—9600
- Data bits—8
- Stop bit—1
- Parity—None
- Flow control—XON/XOFF

The terminal or PC with terminal-emulation software that you connect to a NETGEAR switch has to be configured with these settings. This procedure is described in the documentation supplied with the terminal.

Appropriate cables are available from your local supplier, or you can make your own. To ensure the electromagnetic compatibility of the unit, use only shielded serial cables. For information about the DB-9 console plug connector, see *Connector Pinouts* on page 126.

Logging In for the First Time

To log in and manually configure the IP settings:

1. Connect a terminal or PC with terminal-emulation software to the Supervisory module on the switch or to the console port on the Summit switch.
2. At your terminal, press [Return] one or more times until you see the login prompt.
3. At the login prompt, enter the default user name *admin* to log on with administrator privileges. For example:

login: admin

Administrator capabilities allow you to access all switch functions.

4. The system will ask a series of questions about the default management settings, which allow all forms of management access for convenience in setting the initial configuration. Answer each question based on the level of security needed for the particular management access type.

For more information about logging in to the switch and configuring switch management access, see the *NETGEAR 8800 Series Chassis Switch User Manual*.

5. At the password prompt, press **Return**.

The default user name *admin* has no password assigned to it. When you have successfully logged on to the system, the command line prompt displays the system name (for example, `NETGEAR XCM8810>`) in its prompt.

For more information about how to assign a specific system name, see the *ProSafe 8800 Chassis Switch User Manual*.

6. Assign an IP address and subnetwork mask for VLAN *default* by typing:

configure vlan default ipaddress 123.45.67.8 255.255.255.0

Your changes take effect immediately.

7. Save your configuration changes so that they will be in effect after the next system reboot by typing:

save

The configuration is saved to the configuration database of the Supervisory module modules in the switch.

For more information about saving configuration changes, see the *NETGEAR 8800 Series Chassis Switch User Manual*.

8. When you are finished with these tasks, log out of the switch by typing:

logout

8 Install or Remove Cards

8

This chapter includes the following sections:

- *Install a PoE Daughter Card XCM88P* on page 75
- *Remove a PoE Card XCM88P* on page 77
- *Install an Option Card XCM888F in the Supervisory Module* on page 77
- *Remove a Supervisory Module Option Card* on page 79

Install a PoE Daughter Card XCM88P

The PoE daughter card XCM88P adds PoE functionality to the ports on the XCM8848T module.

You have to remove the I/O module from the 8800 series switch before you install the PoE card.

You need the following tools and equipment to install an PoE card:

- ESD-preventive wrist strap
- #2 Phillips screwdriver
- 3/8-inch flat-blade screwdriver

To install the PoE daughter card XCM88P:

1. Attach the ESD-preventive wrist strap to your bare wrist. If the metal end is not already connected, connect it to the ground receptacle at the top left corner of the chassis.
2. Remove the I/O module from the 8800 series switch, following the instructions in [Remove an XCM8000 Series Module](#) on page 66. Set the module on an ESD-preventive work surface.
3. Identify the daughter card connectors on the I/O module.

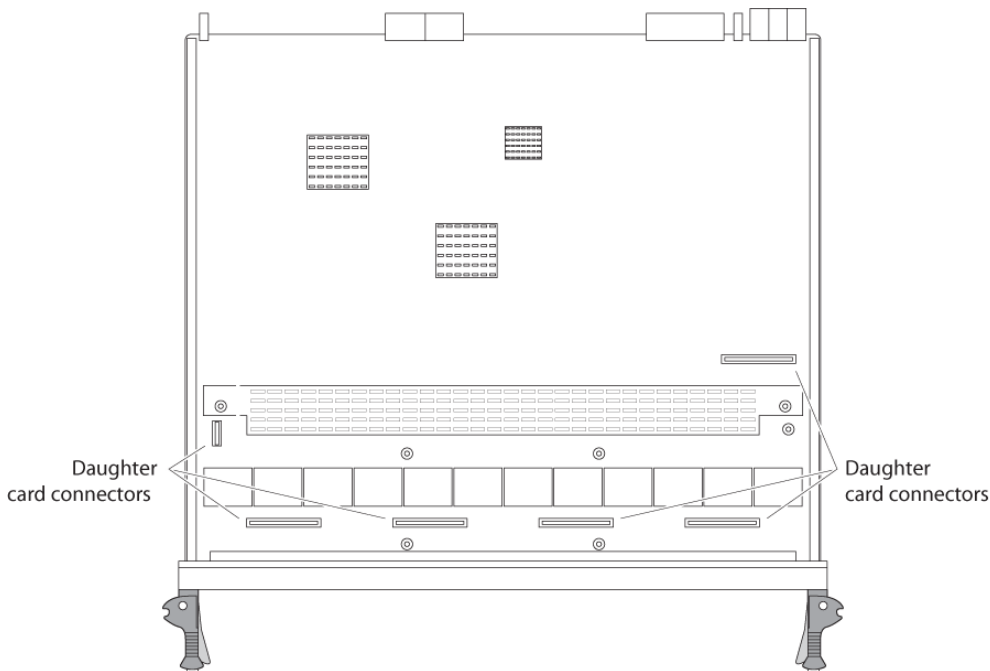

Figure 42. Daughter card connectors on the XCM8848T I/O Module

4. Remove the PoE card XCM88P from its anti-static packaging.
5. Align the PoE card with the connectors on the I/O module (see [Figure 6, Align and finger-tighten the retaining screws, starting with the two middle screws.](#) on page 76).

Following the sequence indicated in the following figure, carefully press the connectors into place. Make sure that all the connectors seat securely.

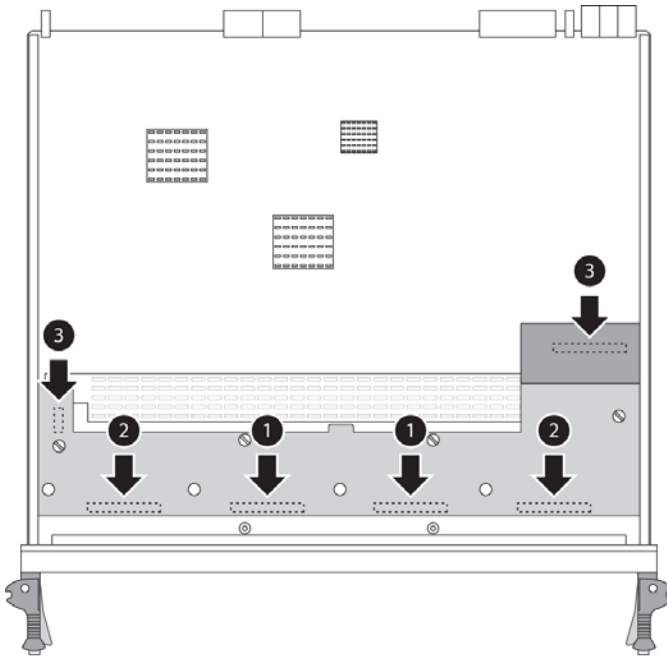

Figure 43. Seating the PoE card XCM88P on the XCM8848T Module

6. Align and finger-tighten the retaining screws, starting with the two middle screws.

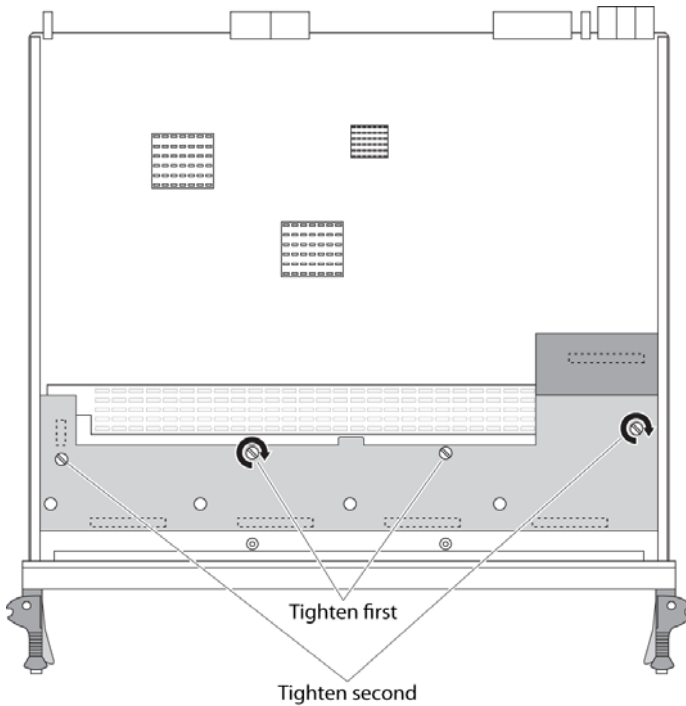

Figure 44. Securing the PoE card XCM88P to the XCM8848T Module

7. Re-install the I/O module in the 8800 series switch following the instructions in *Install an XCM8000 Series Module* on page 62.

Remove a PoE Card XCM88P

To remove a PoE card:

1. Attach the ESD-preventive wrist strap to your bare wrist. If the metal end is not already connected, connect it to the ground receptacle at the top left corner of the chassis.
2. Remove the I/O module from the 8800 series chassis as described in *Remove an XCM8000 Series Module* on page 66.
3. Loosen the spring-loaded captive retaining screws on the PoE card until they pop up.
If the retaining screws are too tight to loosen by hand, use a 3/8-inch flat-blade screwdriver.
4. At each end of the card, grasp the top and bottom edges and carefully lift the card to disengage the connectors.
5. Place the PoE card on an ESD-preventive work surface or into anti-static packaging.
6. If you are replacing the PoE card, install the replacement card as described in *Install a PoE Daughter Card XCM88P* on page 75.
7. Re-install the I/O module as described in *Install an XCM8000 Series Module* on page 62.

Install an Option Card XCM888F in the Supervisory Module

The Supervisory module has a slot for the XCM88F option card, which adds eight 1-gigabit SFP data ports to the Supervisory module.

You need the following tools and equipment to install an option card:

- ESD-preventive wrist strap
- #2 Phillips screwdriver
- #1 Phillips screwdriver
- 3/8-inch straight-tip screwdriver



CAUTION:

The XCM888F option card is not hot-pluggable. You must administratively disable the module and remove it from the switch before you install the option card

To install an option card in a Supervisory module:

1. Attach the ESD-preventive wrist strap to your bare wrist and connect the metal end to the ground receptacle on the top-left corner of the switch chassis.
2. Remove the Supervisory module from the switch as described in [Remove an XCM8000 Series Module](#) on page 66.
3. Loosen the retaining screws on the option slot cover plate and remove the plate.

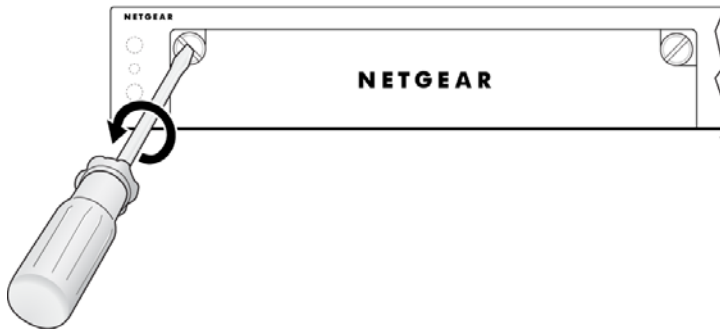

Figure 45. Option slot cover plate

4. Align the option card with the card guides on the module, and carefully slide the option card into the option slot.
5. At the edge of the module, rotate the hot-swap prevention latch up and hold it out of the way. Slide the option card the rest of the way into the slot.

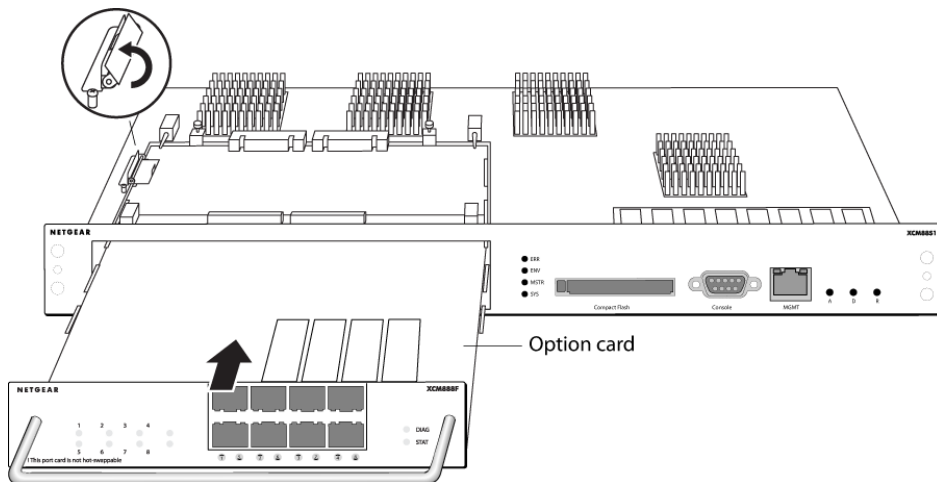

Figure 46. Inserting the Option card XCM88F

6. Release the hot-swap prevention latch and verify that the option card has engaged the alignment pins and connector at the back of the card.

- At the back of the option card, align and finger-tighten the captive retaining screws to secure the card in place.

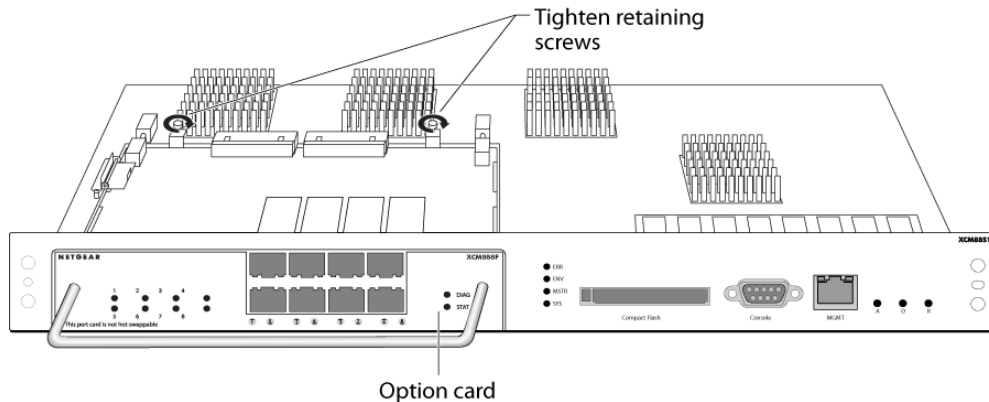

Figure 47. Securing the Option card XCM88F

- Re-install the Supervisory module, following the instructions in *Install an XCM8000 Series Module* on page 62.

Leave the ESD-preventive wrist strap permanently connected to the switch so that it is always available when you need to touch ESD-sensitive components.

Remove a Supervisory Module Option Card

To remove an option card from a Supervisory module:

- Attach an ESD-preventive wrist strap to your bare wrist. If the metal end is not already connected, connect it to the ground receptacle at the top left corner of the chassis.
- Remove the Supervisory module from the 8800 series switch as described in *Remove an XCM8000 Series Module* on page 66.
- At the back of the option card, loosen the spring-loaded captive retaining screws until they pop up (see **Figure 4**).
- At the edge of the module, rotate the hot-swap prevention latch up and hold it out of the way.

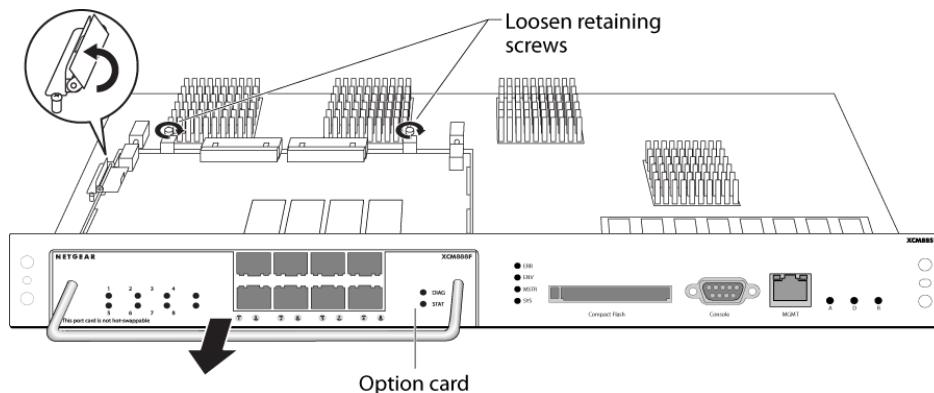

Figure 48. Removing an Option card

5. Using the handle on the option card, pull straight back from the Supervisory module to disconnect the option card from the connectors on the Supervisory module.
6. Slide the option card out of the Supervisory module and immediately place it into anti-static packaging.
7. If you are installing a replacement option card, install the option card as described in *Install an Option Card XCM888F in the Supervisory Module* on page 77.
If you are not installing a replacement option card, install the option slot cover plate over the option card slot.
8. Re-install the Supervisory module, as described in *Install an XCM8000 Series Module* on page 62.

9 AC Power Cord Retainers

9

The AC power cord retainers for switches hold the power connectors in the power sockets and prevent accidental disconnection due to earthquakes, vibration, or other disturbances. Power cord retainers are provided with the 8800 series switches.

This chapter includes the following sections:

- *AC Power Cord Retainer for the XCM8810 Chassis 10-slot* on page 82
- *Power Cord Retainer for the XCM8806 Chassis 6-Slot* on page 84



WARNING!

These switches do not have a switch for turning the power of the unit on and off. Power to the switch is disconnected by removing the wall plug from the electrical outlet. Always be sure that all plugs and electrical outlets are easily accessible.

AC Power Cord Retainer for the XCM8810 Chassis 10-slot

Connect all AC power cords before you install the power cord retainer.

You need the following tools and equipment to install or remove the AC power cord retainer:

- ESD-preventive wrist strap
- #2 Phillips screwdriver

Install the Power Cord Retainer

To install the power cord retainer:

1. Attach the ESD-preventive wrist strap to your bare wrist and connect the metal end to the ground receptacle on the top-left corner of the XCM8810 chassis.
2. Locate the power outlets on the front of the switch.

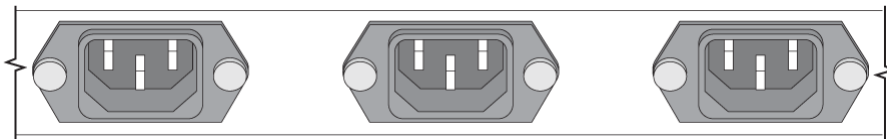

Figure 49. Power outlets on the XCM8810 Switch

3. Connect each AC power cord to a power outlet on the switch as shown in the following figure.

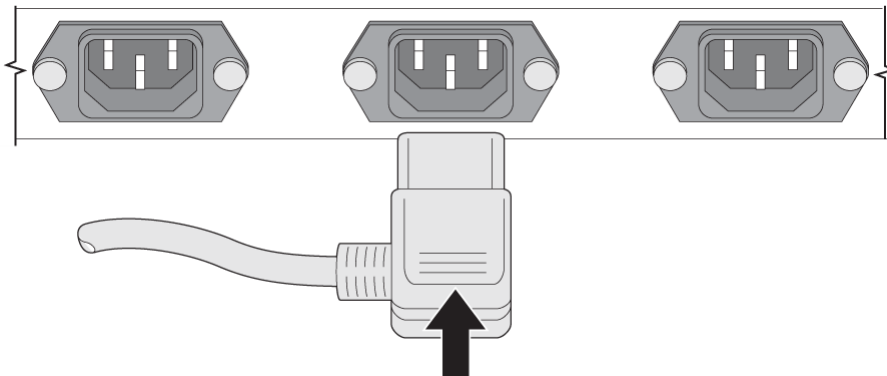

Figure 50. Connecting an AC power cord to the XCM8810 Switch

4. Make sure that each AC power cord is firmly plugged into the power outlet as shown in the following figure.

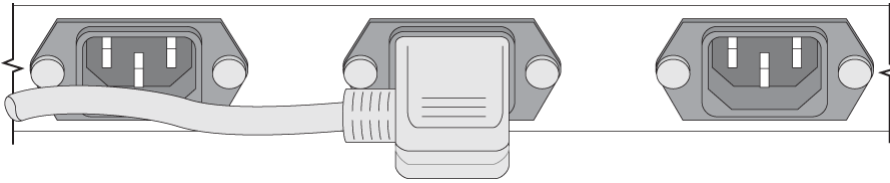

Figure 51. Power cord plugged into the XCM8810 Switch power outlet

5. Align the AC power cord retainer over the AC power cord ends as shown in the following figure.

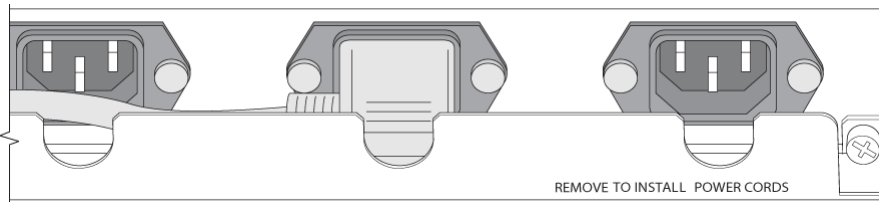

Figure 52. Power cord retainer correctly aligned

6. Tighten the captive screws in the middle and on each end of the power cord retainer (see the following figure).

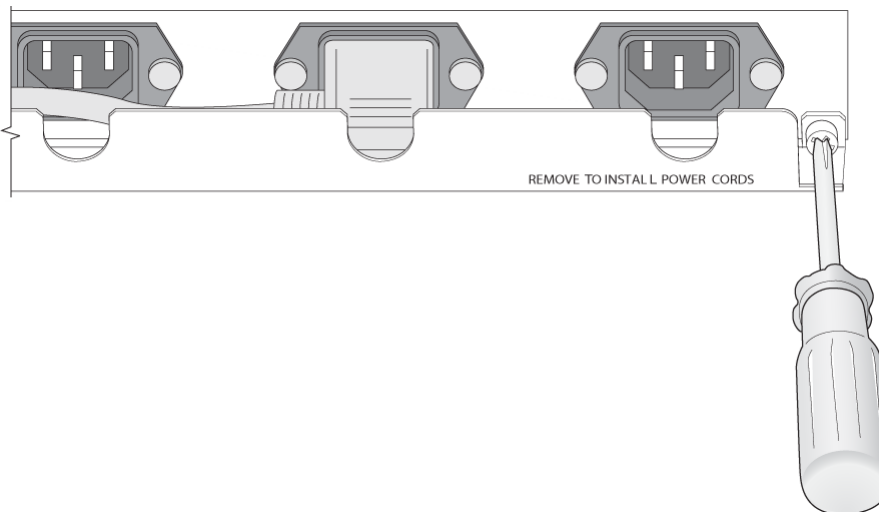

Figure 53. Securing the power cord retainer for the 8800 Series Chassis Switch XCM8810

7. To power the system on, connect the other end of each installed AC power cord to the power source.

Note: Leave the ESD-preventive wrist strap permanently connected to the switch so that it is always available when you need to touch ESD-sensitive components.

Disconnect an XCM8810 Power Cord

To disconnect a power cord:

1. Attach the ESD-preventive wrist strap to your bare wrist and connect the metal end to the ground receptacle on the top left corner of the switch chassis.
2. Disconnect the AC power cord from the power source.
3. Loosen the captive screws in the middle and on each end of the AC power cord retainer, using a #2 Phillips screwdriver.
4. Remove the AC power cord retainer from the front of the switch.
5. Remove the end of the AC power cord from the power outlet(s) on the front of the switch.

Note: Leave the ESD-preventive wrist strap permanently connected to the switch so that it is always available when you need to touch ESD-sensitive components.

Power Cord Retainer for the XCM8806 Chassis 6-Slot

Connect all AC power cords before you install the power cord retainer.

You need the following tools and equipment before installing or removing the AC power cord retainer:

- ESD-preventive wrist strap
- #2 Phillips screwdriver

Install the Power Cord Retainer

To install the power cord retainer:

1. Attach the ESD-preventive wrist strap to your wrist and connect the metal end to the ground receptacle on the top-left corner of the switch front panel.
2. Starting at the left, insert the plug of each power cord into the power connectors on the switch, and lift each installed power cord over the previous plug (see [Figure 54](#)).

Verify that all installed power cords are firmly plugged into the power connectors.

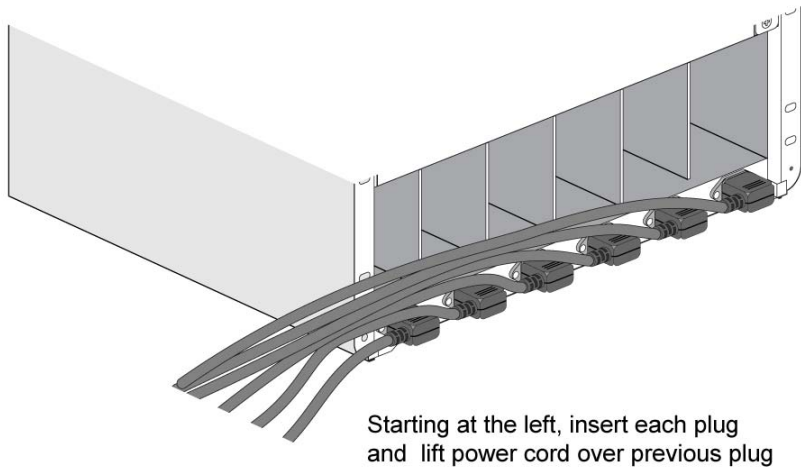

Figure 54. Installing and routing the AC power cords

3. Hold the power cord retainer as shown in the following figure.

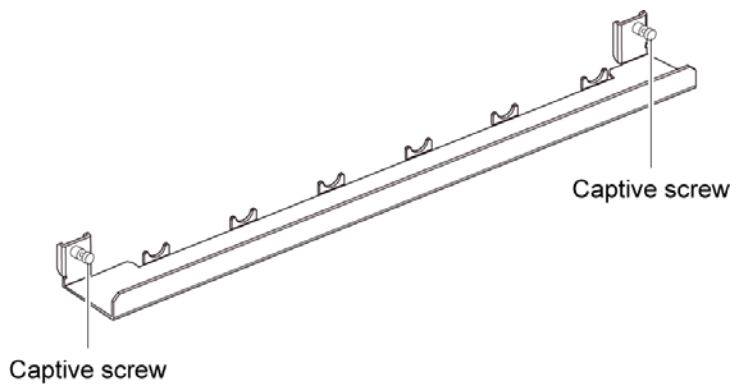

Figure 55. XCM8806 AC power cord retainer

4. Place the retainer against the switch as shown in [Figure](#) . Tighten the screw at each end of the retainer.

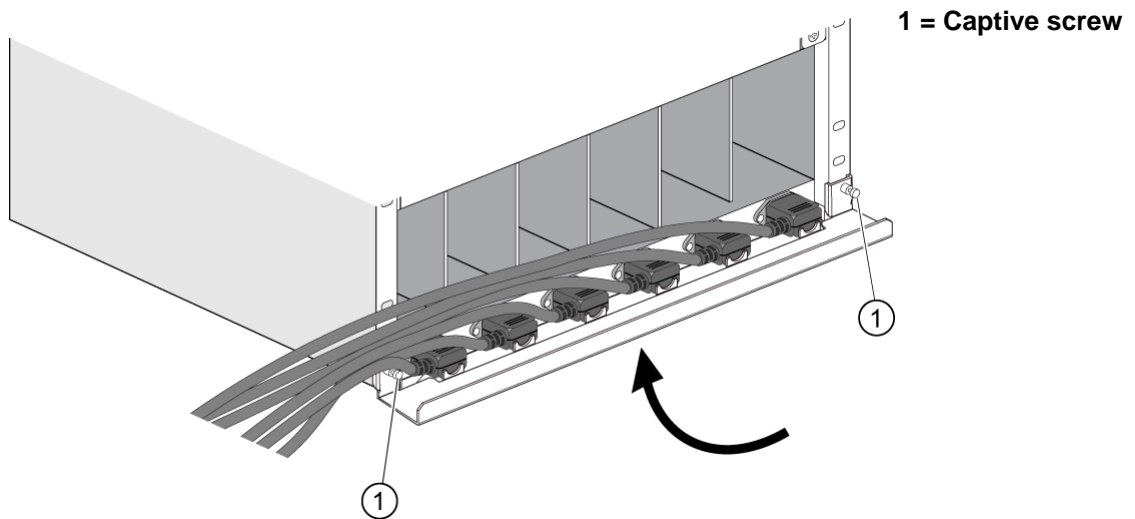

Figure 56. Securing the XCM8806 AC power cord retainer

5. Starting from the left, lay the first four power cords into the retainer (see [Figure](#)).
6. Lay the last two power cords on top of the bottom four cords (see [Figure](#)).

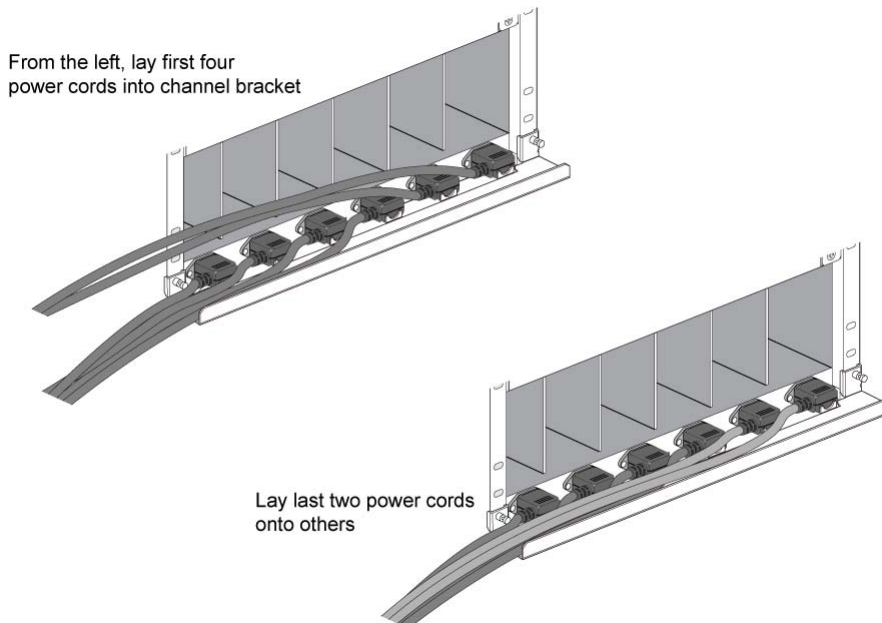

Figure 57. Routing the power cords in the retainer

Note: Leave the ESD-preventive wrist strap permanently connected to the switch, so that the strap is always available when you need to handle ESD-sensitive components.

Remove the XCM8806 Power Cord Retainer

To remove the power cord retainer:

1. Attach the ESD-preventive wrist strap to your wrist and connect the metal end to the ground receptacle on the top-left corner of the switch front panel.
2. Using a #2 Phillips screwdriver, loosen the captive screw located on each end of the power cord retainer.
3. Remove the retainer from the switch.

Note: Leave the ESD-preventive wrist strap permanently connected to the switch, so that the strap is always available when you need to handle ESD-sensitive components.

10. Cable Management

10

This chapter includes the following sections:

- *Cable Management* on page 89
- *Cable Holders and Cable Clips* on page 89

The cable holders and cable clips provide a way to organize and contain masses of cables connected to a switch. This chapter describes how to install and use these cable management accessories.

Cable Management

Interlocking cable holders and cable clips for the switches provide free-standing, rigid structural support for individual cables and cable bundles in front of the switch. You can use the cable holders and cable clips individually or connect them together to manage multiple cable bundles.

The cable management accessories keep cables collected in one place, rather than allowing them to hang freely. If you need to remove a module from the chassis for replacement or repair, the cable clips and holders maintain the cable arrangement in front of the chassis for ease of connection when you reinsert the module.

Cable Holders and Cable Clips

When you use the cable holders and the cable clips, NETGEAR recommends the following:

- Attach the cables to the holders by slipping the cable through the opening.
- Connect the cable holders, if you need more than one. (Refer to [Cable Holders](#) on page 90.)
- If you need more than one cable clip for a bundle, connect the clips together before you route the cables through the clips. (Refer to [Cable Clips](#) on page 92.)
- To form a cable bundle, thread the cables through the clips.

The following figure shows the cable holders and clips being used to manage a group of cables.

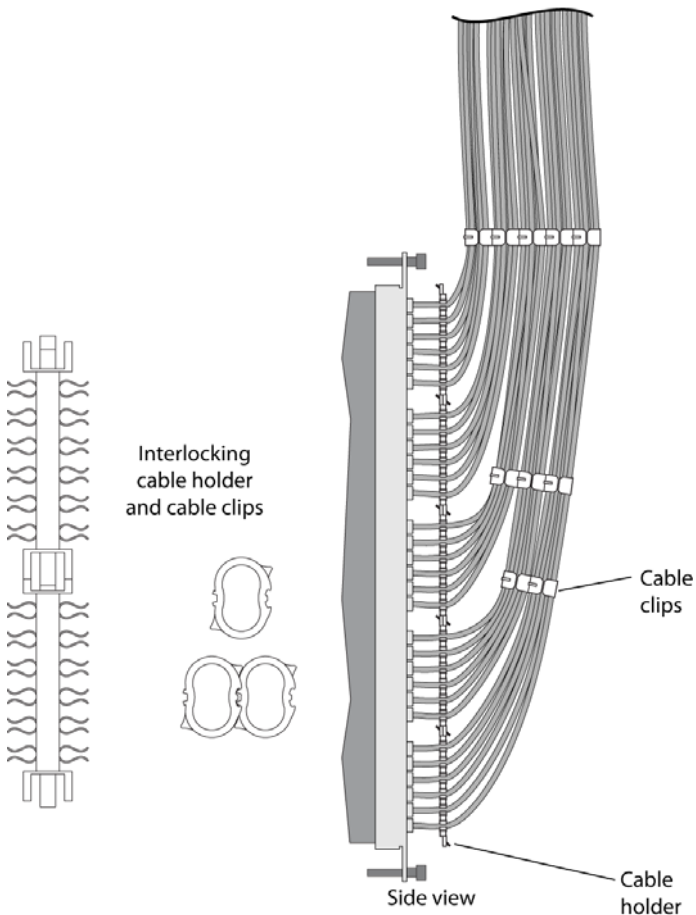

Figure 58. Cable holders and clips

Cable Holders

Each cable holder holds up to 12 separate cables, with 6 on each side. Connect cable holders end to end as needed to accommodate the number of cables you need to organize.

To connect the cable holders:

1. Hold two cable holders as shown in [Figure 59](#).
Make sure that one locking tab at the joint is on top and the other is on the bottom.

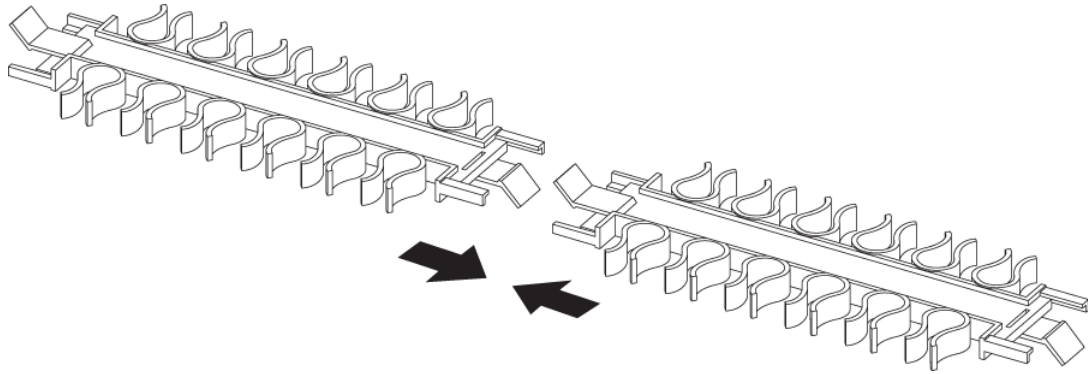

Figure 59. Connecting cable holders

2. Slide the ends together and push the cable holders together until you feel them snap into place.

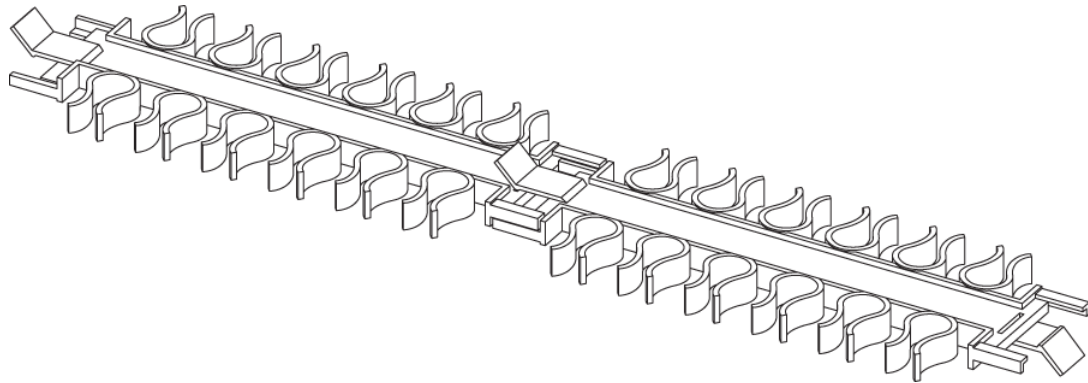

Figure 60. Connected cable holders

3. Connect as many cable holders together as you need to manage your cable bundles.
4. To disconnect the holders, grasp one in each hand firmly and carefully pull them apart.

Cable Clips

To connect the cable clips:

1. Hold two clips next to each other with the split sides facing the same way. Slide the connecting grooves together.

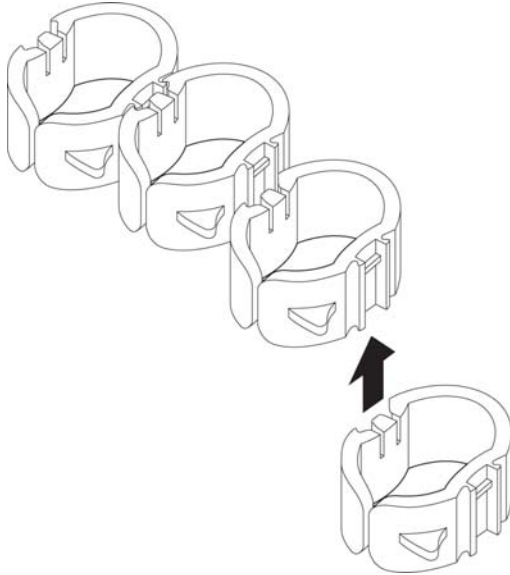

Figure 61. Connecting cable clips

2. Press the clips together until the connectors lock into place.

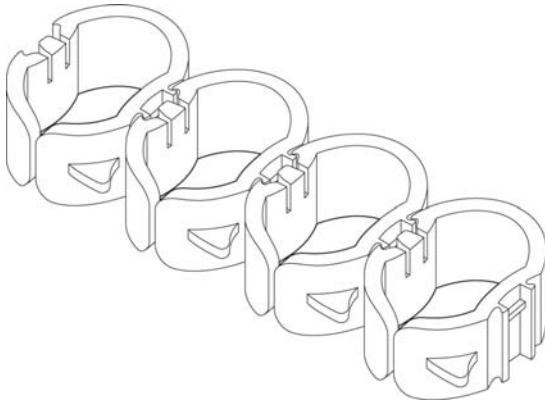

Figure 62. Cable clip chain

3. Connect as many cable clips together as you need to manage your cable bundles.
4. To disconnect the cable clips, push on the bottom ring while holding the top ring steady.

Replace 8800 Series Chassis Components

11

This chapter describes how to replace components in the following switches:

- XCM8810 switch
- XCM8806 switch

The chapter includes the following sections:

- *Replace the Fan Tray* on page 93
- *Replace the PSU/Fan Controller* on page 97

Replace the Fan Tray

The 8800 series switch has one fan tray that is accessible from the front of the switch.

Note: To avoid long periods of operation without forced air cooling, make sure you have the replacement fan tray ready before you start the replacement procedure.

Pre-Installation Requirements

You need the following tools and equipment to replace a fan tray in a 8800 series switch:

- ESD-preventive wrist strap
- #2 Phillips screwdriver
- Replacement 8800 series fan tray

Remove the Fan Tray

To remove a fan tray from the 8800 series switch:

1. Attach the ESD-preventive wrist strap to your bare wrist and connect the metal end to the ground receptacle on the top left corner of the switch chassis.

2. Locate the captive screws at the top and bottom of the fan tray.
3. Use a #2 Phillips screwdriver to loosen each captive screw (see [Figure 63](#) and [Figure 64](#)).

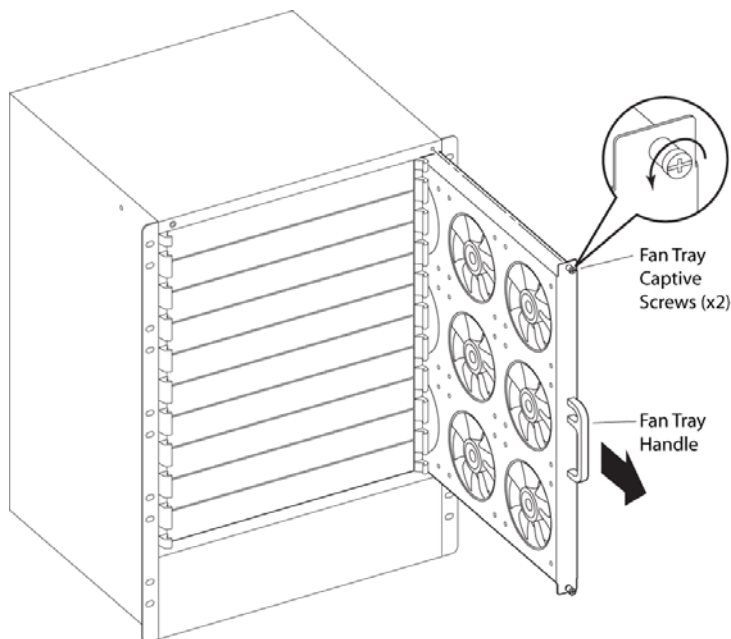

Figure 63. Removing the Fan Tray from the XCM8810 Switch

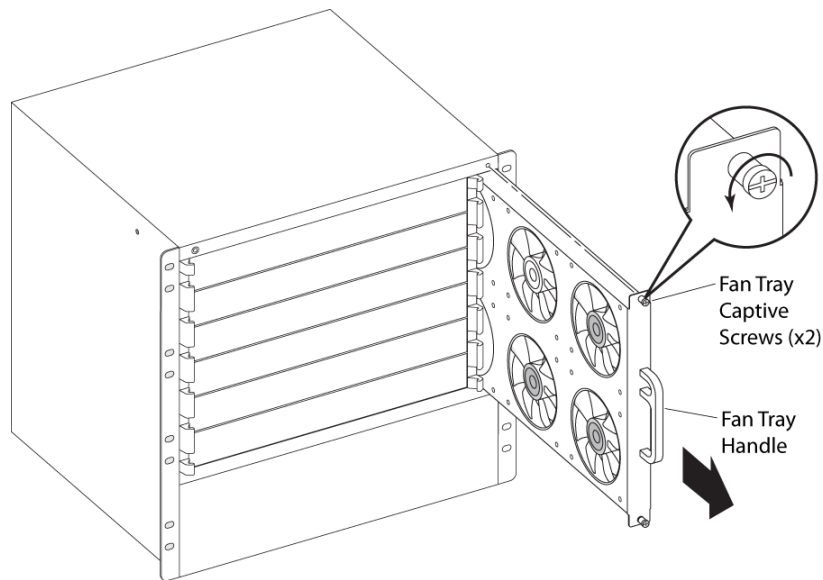

Figure 64. Removing the fan tray from the XCM8806 Switch

4. Use the fan tray handle to pull the fan tray half-way out from the fan tray slot. This action disconnects the fan tray from the switch power.

Wait for the fan blades to stop turning before continuing with this procedure.



WARNING!

Be sure that all fan blade motion has ceased before continuing to remove the fan tray.

5. Support the bottom of the fan tray with your free hand as you use the handle to slide the fan tray completely out from the fan tray slot.



CAUTION:

Be sure that both hands are used to support the weight of the fan tray during removal.

Note: Leave the ESD-preventive wrist strap permanently connected to the switch so that it is always available when you need to touch ESD-sensitive components.

Install a Replacement Fan Tray

To install the replacement fan tray:

1. Attach the ESD-preventive wrist strap to your bare wrist and connect the metal end to the ground receptacle on the top left corner of the switch.
2. Support the bottom of the fan tray with one hand as you lift the fan tray by the handle using the other hand. Align the spare fan tray with the fan tray slot on the switch, and then slide the fan tray into place in the switch (see [Figure 65](#) and [Figure 66](#)).



CAUTION:

Always use both hands to support the weight of the fan tray during installation.

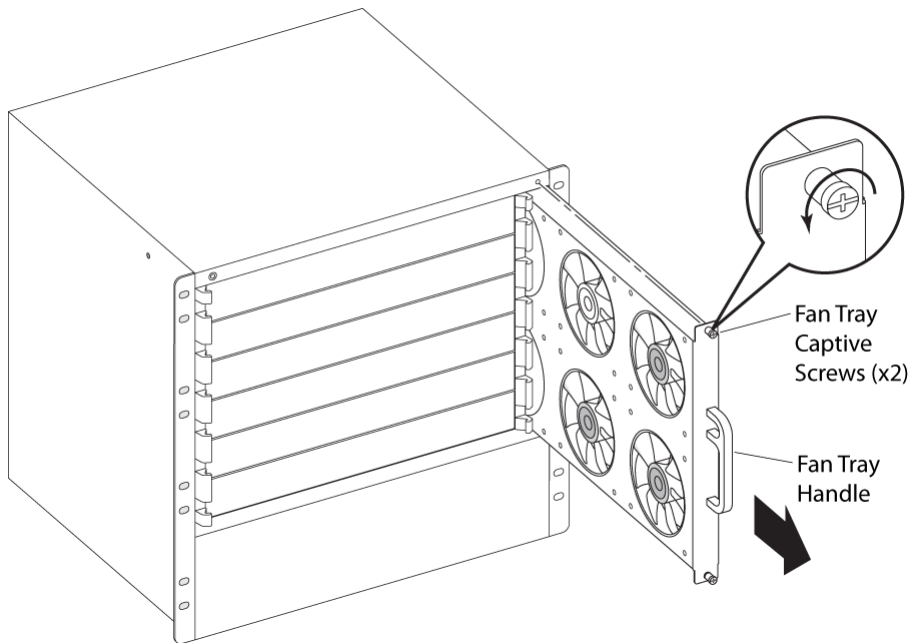

Figure 65. Installing the Fan Tray in the XCM8810 Switch

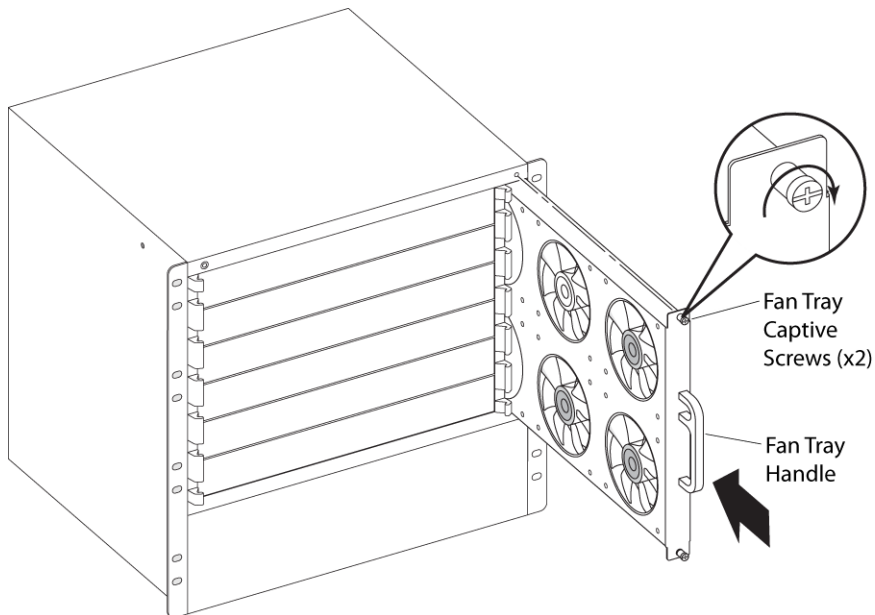

Figure 66. Installing the Fan Tray in the XCM8806 Switch

3. Use a #2 Phillips screwdriver to tighten the screws ([Figure 65](#)).

Leave the ESD-preventive wrist strap permanently connected to the switch so that it is always available when you need to touch ESD-sensitive components.

Replace the PSU/Fan Controller

The 8800 series switch has two PSU/fan controllers behind an access panel on the rear of the switch chassis.

Note: The PSU/fan controllers are installed in the system before it is shipped to customers. For a new chassis installation, access to the PSU/fan controllers or to the back of the chassis is not required.

Pre-installation Requirements

Make sure that you have access to the back of the switch.

You need the following tools and equipment to replace a 8800 series PSU/fan controller:

- ESD-preventive wrist strap
- #1 Phillips screwdriver
- #2 Phillips screwdriver
- Replacement 8800 series PSU/fan controller

Remove the PSU/Fan Controller

To remove a PSU/fan controller from the 8800 series switch:

1. Attach the ESD-preventive wrist strap to your wrist and connect the metal end to the ground receptacle on the front top-left corner of the switch.

2. Locate the eight captive screws on the PSU/fan controller access cover at the back of the 8800 series switch (see [Figure 67](#) and [Figure 68](#)).

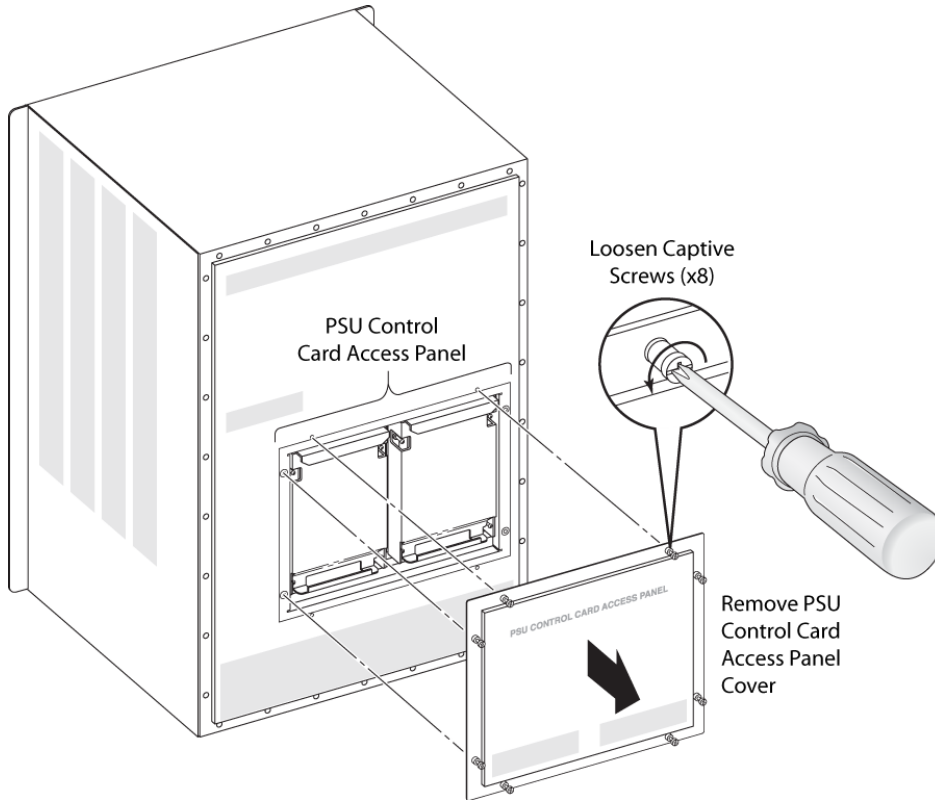

Figure 67. Removing the access cover from the XCM8810 Switch

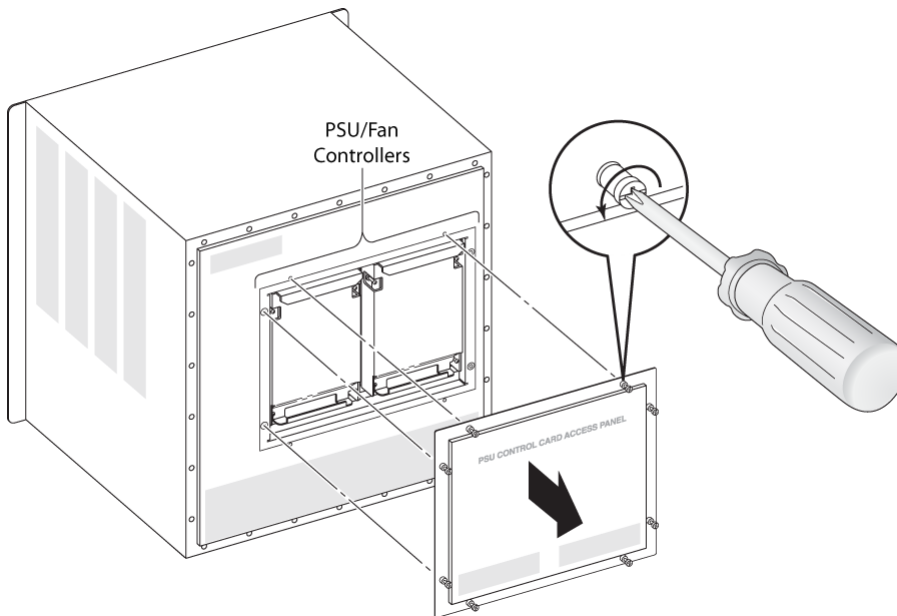

Figure 68. Removing the access cover from the XCM8806 Switch

3. Using a #2 Phillips screwdriver, loosen all eight captive screws on the PSU/fan controller access cover.
4. Pull the access cover away from the back of the switch.
The PSU/fan controllers are visible in the controller recess.
5. Locate the four captive screws on the PSU/fan controller you are replacing.

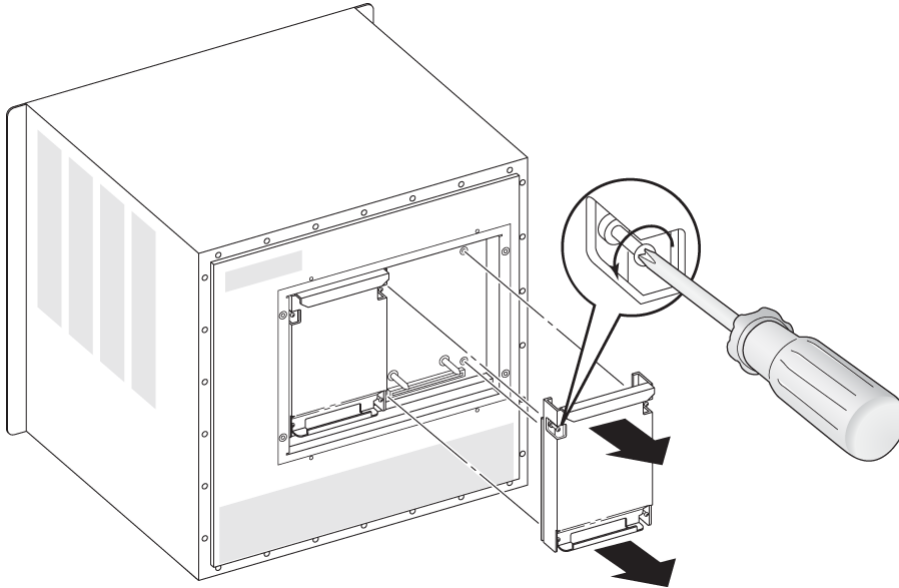

Figure 69. Removing the PSU/Fan Controller (XCM8806 Switch shown)

6. Using a #1 Phillips screwdriver, loosen all four captive screws on the PSU/fan controller.
7. Pull equally on the upper and lower handles of the PSU/fan controller to disconnect the controller connector.

Leave the ESD-preventive wrist strap permanently connected to the switch, so that the strap is always available when you need to handle ESD-sensitive components.

Install the Replacement PSU/Fan Controller

To install a replacement PSU/fan controller in the 8800 series switch:

1. Attach the ESD-preventive wrist strap to your bare wrist and connect the metal end to the ground receptacle on the front top-left corner of the switch.
2. Align the guide pins in the empty controller recess with the holes on the replacement PSU/fan controller.
3. Push the replacement PSU/fan controller into the empty controller recess until the four captive screws on the replacement controller are in alignment.
4. Using a #1 Phillips screwdriver, tighten all four captive screws on the replacement controller.
5. Align the guide pins on the access cover with the holes at the edges of the controller recess.

6. Push the access cover over the controller recess until the captive screws on the access cover are in alignment.
7. Using a #2 Phillips screwdriver, tighten all the captive screws on the access cover.

Leave the ESD-preventive wrist strap permanently connected to the switch, so that the strap is always available when you need to handle ESD-sensitive components.

12 Repack an 8800 Series Chassis

12

This chapter includes the following sections:

- *Safety Information* on page 102
- *Repack the XCM8810 Chassis* on page 102
- *Repack the XCM8806 Chassis* on page 104

The chapter describes how to remove a 8800 series chassis from an equipment rack and repack the chassis for shipping. To repack a 8800 series chassis, use the original shipping crate or box and packing materials.

Note: Read the information in this chapter thoroughly before you attempt to remove a 8800 series chassis.

Safety Information

**CAUTION:**

Correct lifting procedures for a 8800 series chassis require two or more people.

Only trained service personnel should perform service to the switches and their components. Trained service personnel have read all related installation manuals, have the technical training and experience necessary to be aware of the hazards to which they are exposed in performing a task, and are aware of measures to minimize the danger to themselves or other persons.

See [Appendix A, Safety Information](#) for additional safety information and [Appendix B, Technical Specifications](#) for additional information regarding regulatory compliance certifications.

**CAUTION:**

Before you lift a 8800 series chassis, make sure the chassis is empty to prevent unnecessary weight. This will also prevent damage to the system components due to possible chassis flex when lifting.

Required Tools and Equipment

You need the following tools and equipment to repack a 8800 series chassis:

- ESD-preventive wrist strap
- Support bracket that was shipped with the chassis
- Four rack-mount screws appropriate to your organization's equipment rack
- Screwdriver appropriate to the rack-mount screws
- Original packing materials from the chassis
- Packing tape
- Nylon strapping and crimping tool

Repack the XCM8810 Chassis

To repack the chassis:

1. Attach the ESD-preventive wrist strap to your bare wrist and connect the metal end to the ground receptacle on the chassis front panel.
2. Remove all modules and power supplies from the chassis. Follow correct procedures for removing components.

3. Using four mounting screws, attach the support bracket to the equipment rack immediately below the chassis.
4. Remove the eight mounting screws that secure the chassis to the equipment rack.
5. On each side of the chassis, place one hand in the empty power supply bay and the other hand in the recessed hand-hold on the back panel of the chassis (see [Figure 70](#)).



CAUTION:

Do not use the fan tray handle to lift or maneuver the XCM8810 chassis. This handle is not designed to support the weight of the chassis.

6. Slowly guide the chassis out of the equipment rack using the support bracket for support.
7. Carefully lift the chassis off the support bracket and lower it onto wood pallet.

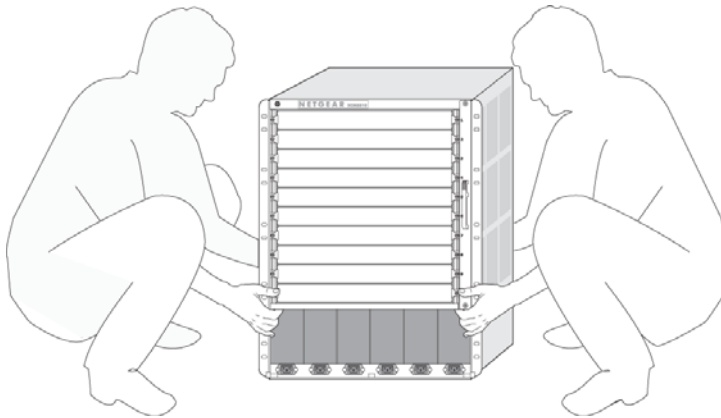

Figure 70. Correct method for lifting the XCM8810 Chassis

8. At each corner, attach the chassis to the restraining brackets on the shipping pallet.

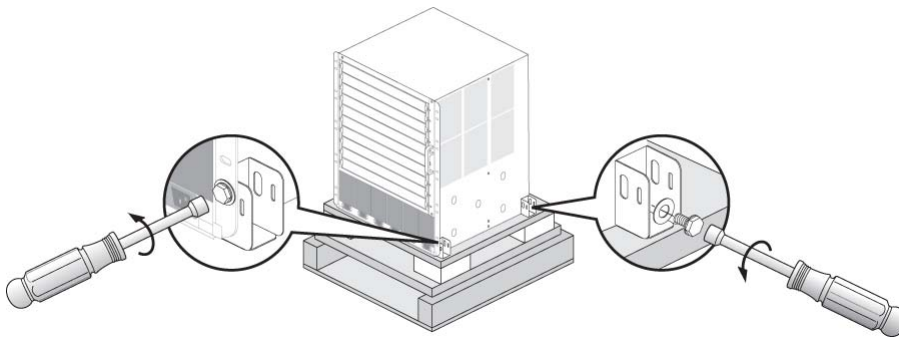

Figure 71. Reocrating the XCM8810 Chassis

9. Slide the shipping carton down over the XCM8810 chassis.
10. Place the packing foam on top of the XCM8810 chassis
11. Close the top flaps on the shipping carton and seal them with packing tape.
12. Secure the shipping carton with nylon straps.

Note: Nylon straps are necessary to secure the upper shipping carton to the pallet.

Repack the XCM8806 Chassis

To repack the chassis:

1. Attach the ESD-preventive wrist strap to your bare wrist and connect the metal end to the ground receptacle on the chassis front panel.
2. Remove all modules and power supplies from the chassis. Follow correct procedures for removing components.
3. Using four rack mounting screws, attach the 19-inch support bracket to the equipment rack immediately below the chassis.
4. Remove the eight rack mounting screws that secure the chassis to the equipment rack.
5. On each side of the chassis, place one hand in the empty power supply bay and the other hand in the recessed hand-hold on the back panel of the chassis.



CAUTION:

Do not use the fan tray handle to lift or maneuver the XCM8806 chassis. This handle is not designed to support the weight of the chassis.

6. Slowly guide the chassis out of the equipment rack using the support bracket for support.
7. Carefully lift the chassis off the support bracket and lower it onto the foam cushion in the shipping carton base.

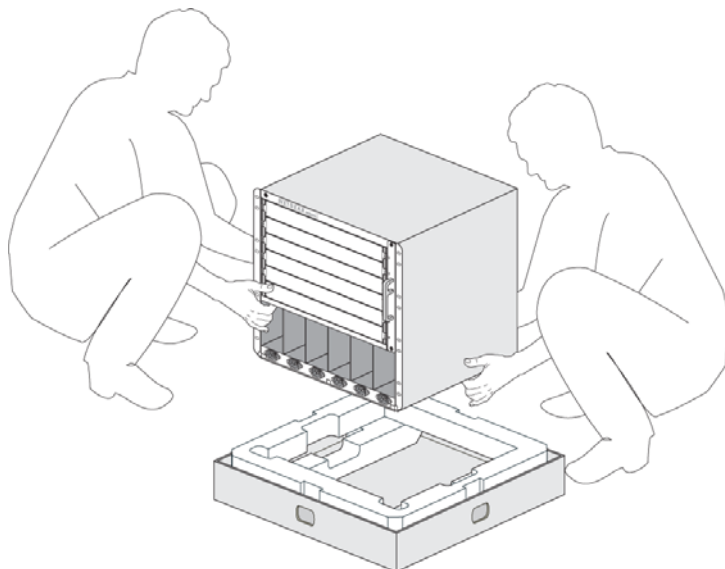

Figure 72. Setting the XCM8806 Chassis onto the foam cushion

8. Set the corner braces in place and slide the top of the shipping carton down and over the chassis.

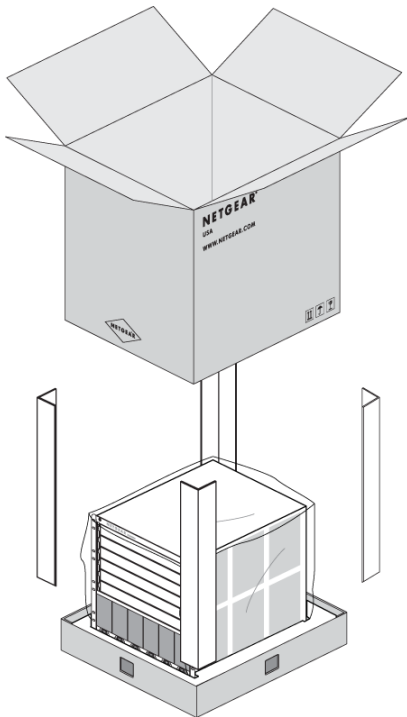

Figure 73. Placing the carton over the XCM8806 Chassis

9. Insert the clip locks.
 - a. Squeeze the prongs together in the middle of the clip lock.
 - b. Push the clip lock into the carton opening and release the prongs.Repeat these steps to insert each of the remaining clip locks.



CAUTION:

Proper installation of the clip locks is critical for safe shipment of the XCM8806 chassis. Make sure that the clip locks are secure and accurately installed.

10. Place the packing foam material on top of the chassis.
11. Close the top flaps on the shipping carton and seal them with packing tape.

A Safety Information



WARNING!

Read the following safety information thoroughly before installing your products. Failure to follow this safety information can lead to personal injury or damage to the equipment.

Only trained service personnel should perform service to the switches and their components. Trained service personnel have read all related installation manuals, have the technical training and experience necessary to be aware of the hazards to which they are exposed in performing a task, and are aware of measures to minimize the danger to themselves or other persons.

This appendix includes the following sections:

- *Considerations Before Installing* on page 106
- *Installing Power Supply Units* on page 108
- *Maintenance Safety* on page 107
- *General Safety Precautions* on page 107
- *Cable Routing for LAN Systems* on page 110
- *Selecting Power Supply Cords* on page 109
- *Battery Replacement and Disposal* on page 111
- *Fiber Optic Ports—Optical Safety* on page 111
- *Sicherheitshinweise* on page 112 (Safety information in German)

Considerations Before Installing

Consider the following items before installing equipment.

- The system is designed to operate in a typical environmentally controlled Telco environment. Choose a site that has the following characteristics:
 - Temperature- and humidity-controlled, such that the maximum ambient room temperature shall not exceed 40°C (104°F)
 - Clean and free from airborne materials that can conduct electricity.
 - Well ventilated and away from sources of heat including direct sunlight.

- Away from sources of vibration or physical shock.
- Isolated from strong electromagnetic fields produced by electrical devices.
- Secured, enclosed, and restricted-access, ensuring that only trained and qualified service personnel have access to the equipment.
- Establish at least 3 inches clearance on all sides for effective ventilation. Do not obstruct the air intake vent on the front, side, or rear ventilation grills. Locate the system away from heat sources.
- Make sure that your equipment is placed in an area that accommodates the power consumption and component heat dissipation specifications.
- Make sure that your power supplies meet the site DC power or AC power requirements of all network equipment.

Maintenance Safety

When you perform maintenance procedures on your equipment, follow these recommendations:

- Use only original accessories or components approved for use with this system. Failure to follow these instructions may damage the equipment or violate required safety and EMC regulations.
- The chassis cover should only be removed by NETGEAR personnel. This system contains no customer serviceable components. Repairs to the system must be performed by a factory service technician.
- To remove power from the system, you must unplug all power cords from wall outlets. The power cord is the disconnect device to the main power source.
- Disconnect all power before removing the back panel of any NETGEAR switch, unless otherwise instructed by a product specific maintenance procedure.
- Disconnect all power cords before working near power supplies, unless otherwise instructed by a product-specific maintenance procedure.
- When you handle modules, optical devices, power supplies, or other modular accessories put on an ESD-preventive wrist strap to reduce the risk of electronic damage to the equipment. Connect the other end of the strap to the ESD connector on the front of the chassis. Leave the ESD-preventive wrist strap permanently attached to the chassis so that it is always available when you need to handle ESD-sensitive components.
- Install all cables in a manner that avoids strain. Use tie wraps or other strain relief devices.
- Replace a power cord immediately if it shows any signs of damage.

General Safety Precautions

Follow these guidelines:

- Do not attempt to lift objects that you think are too heavy for you.

- When you install equipment in a rack, load heavier devices in the lower half of the rack first to avoid making the rack top-heavy.
- Only use tools and equipment that are in perfect condition. Do not use equipment with visible damage.
- Route cables in a manner that prevents possible damage to the cables and avoids causing accidents, such as tripping.

Installing Power Supply Units

For the ratings and power requirements of each power supply unit, see [Appendix B, Technical Specifications](#) or the data sheet for the power supply at www.netgear.com.



WARNING!

Be sure that the requirements listed in this section are satisfied when installing all power supplies.

When you install power supplies:

- Plug power supplies only into properly grounded electrical outlets to help prevent electrical shock and comply with international safety standards.
- Use only power cords that are certified for use within the country of use. Do not attempt to modify AC power cords.
- Make sure the wall outlet is installed near the equipment and is easily accessible for quick disconnect.
- Make sure the voltage and frequency of your power outlet match the system electrical ratings for the equipment. The building and/or power source has to provide overload protection.
- Use a surge suppressor, line conditioner, or uninterruptible power supply to protect the system from momentary increases or decreases in electrical power.
- When inserting a hot-swappable power supply into the bay, do not use excessive force.
- When you install multiple power supplies, connect each power supply to a different, independent over-current protection device, such as a circuit breaker. If a single power source fails, it will affect only that power supply to which it is connected. If all the power supplies on a single switch are connected to the same power source, the entire switch is vulnerable to a power failure.



WARNING!

The power supplies do not have switches for turning the unit on and off. Remove the wall plug from the electrical outlet to disconnect the power from an AC power supply. Make sure that this connection is easily accessible.

Do not connect a power supply to an electrical outlet when the power supply is not installed in the chassis; doing so would expose a hazardous energy and poses a potential shock and fire hazard.

Do not put your hand into an open power supply bay when a power supply is not present. Empty power supply bays require a cover plate at all times.

Selecting Power Supply Cords

The following power cord requirements apply to cords used with the 700W PSU XCM888PS1:

- The power supply cord needs to be agency-certified for country of use, and rated at 10A by in-country regulatory authority.
- The power supply cord has to have an IEC 320 C13, 90-degree angle plug to connect to the IEC320 C14 connector on the power supply.
- The power cord requires an appropriately rated and approved wall plug applicable to the country of installation.
- For cords up to 6 feet (2 m) long, the wire size has to be 18 AWG (.75 mm²) minimum; over 6 feet, the minimum wire size is 16 AWG (1.0 mm²).



WARNING!

Make sure that the source outlet is properly grounded according to the country's local electrical requirements before plugging the AC supply power cord into a PSU.

For specific product input power requirements refer to the data sheet of the product or PSU at www.netgear.com or to *Appendix B, Technical Specifications*.

Note: This equipment is not intended to be directly powered by power distribution systems where phase-phase voltages exceed 240V AC (2P+PE), such as those used in Norway, France, and other countries. For these applications it is recommended that a transformer be used to step down the voltage to < 240V AC from phase-phase, or that you make a connection to a (P+N+PE) power

distribution where voltages do not exceed 240V AC.

All installations should confirm that the product is reliably grounded according to the country's local electrical codes.

Note: Building codes vary worldwide; therefore, NETGEAR strongly recommends that you consult an electrical contractor to ensure proper equipment grounding and power distribution for your specific installation & country.

Cable Routing for LAN Systems

The 8800 series switches meet the requirements for LAN system equipment. LAN systems are designed for intra-building installations; that is, cable runs between devices needs to be in the same building as the connected units.

This equipment can be connected between buildings if any one of the following conditions is true:

- Cable runs between buildings are less than 140 feet long.
- Cable runs between buildings are directly buried.
- Cable runs between buildings are in an underground conduit, where a continuous metallic cable shield or a continuous metallic conduit containing the cable is bonded to each building grounding electrode system.



CAUTION:

Failure to follow these requirements for cable routing conditions may expose the user to electrical shock and expose the unit to errors or damage.



WARNING!

The intra-building ports of the equipment or sub-assembly are suitable for connection to intrabuilding or unexposed wiring or cabling only. The intra-building port(s) of the equipment or sub-assembly MUST NOT be metallically connected to interfaces that connect to the outside plant (OSP) or its wiring. These interfaces are designed for use as intra-building interfaces only

(Type 2 or Type 4 ports as described in GR-1089-CORE, Issue 4) and require isolation from the exposed OSP cabling. The addition of Primary Protectors is not sufficient protection in order to connect these interfaces metallicity to OSP wiring.

PoE Devices

When connecting power over Ethernet (PoE) devices to a PoE-capable I/O module, all connections between the PoE device and the module have to be inside the same building and use a low-voltage power distribution system per IEEE 802.3af.

Battery Replacement and Disposal

Batteries included with your products are encapsulated and have to be replaced by qualified service personnel only. Contact your NETGEAR service personnel for product replacement. Do not attempt to replace the battery. If these instructions are disregarded and replacement of these batteries is attempted, the following guidelines need to be followed to avoid danger of explosion:

1. Replace with same or equivalent battery type as recommended by the battery manufacturer.
2. Dispose of battery in accordance with the battery manufacturer's recommendation.

Fiber Optic Ports—Optical Safety

The following safety warnings apply to all optical devices used in NETGEAR equipment that are removable or directly installed in an I/O module or chassis system. Such devices include but are not limited to gigabit interface converters (GBICs), small form factor pluggable (SFP) modules (or mini-GBICs), XENPAK transceivers, and XFP laser optic modules.



WARNING!

Laser optic modules become very hot after prolonged use. Take care when removing a laser optic module from the chassis or option card. If the laser optic module is too hot to touch, disengage the laser optic module and allow it to cool before removing it completely.



WARNING!

When working with laser optic modules, always take the following precautions to avoid exposure to hazardous radiation.

- Never look at the transmit LED/laser through a magnifying device while it is powered on.
- Never look directly at a fiber port on the switch or at the ends of a fiber cable when they are powered on.
- Invisible laser radiation can occur when the connectors are open. Avoid direct eye exposure to the beam when optical connections are unplugged.
- Never alter, modify, or change an optical device in any way other than suggested in this document.

GBIC, SFP (Mini-GBIC), XENPAK, and XFP Regulatory Compliance

NETGEAR pluggable optical modules meet the following regulatory requirements:

- Class 1 Laser Product
- EN60825-1+A2:2001 or later, European laser standard
- FCC 21 CFR Chapter 1, Subchapter J in accordance with FDA & CDRH requirements
- Application of CE Mark in accordance with 89/336/EEC EMC and 73/23/EEC Low Voltage Directives
- UL and/or CSA registered component for North America
- 47 CFR Part 15, Class A when installed into NETGEAR products

Note: NETGEAR optical modules are tested to work in all supported NETGEAR switches. We recommend that all customers use NETGEAR optical modules in their NETGEAR switches. NETGEAR assumes no liability for third-party optical modules. Although NETGEAR does not block third-party optical modules, we cannot ensure that all third-party optical modules operate properly in all NETGEAR switches. The customer assumes all risks associated with using third-party optical modules in NETGEAR switches.

Sicherheitshinweise



WARNING!

Vor der Installation der Produkte von NETGEAR sind die nachfolgenden Sicherheitshinweise aufmerksam zu lesen. Die Nichtbeachtung dieser Sicherheitshinweise kann zu Verletzungen oder Schäden an der Ausrüstung führen.

Installation, Wartung und Ausbau eines Switch, einer Grundplatte oder einer seiner Komponenten dürfen nur von geschultem und qualifiziertem Servicepersonal durchgeführt werden! Geschulte und qualifizierte Servicetechniker verfügen über die erforderliche technische Ausbildung und Erfahrung, um mögliche Gefahren bei der Durchführung von Servicearbeiten zu erkennen und Maßnahmen zur Minimierung der Gefahr für sich bzw. andere zu treffen.

Hinweise zur Installation



WARNING!

Beachten Sie vor der Installation der Ausrüstung folgende Punkte.

Stellen Sie sicher, dass die nachfolgend aufgeführten Bedingungen erfüllt sind:

- Das System ist für den Einsatz in einer typischen Umgebung gemäß Telco-Vorgaben vorgesehen. Wählen Sie einen Aufstellort mit den folgenden Eigenschaften:
 - Innenbereich mit Temperatur- und Feuchtigkeitsregelung, wobei die maximale Raumtemperatur 40°C (104°F) nicht überschreiten darf.
 - Sauber und frei von elektrisch aufladbaren Teilchen in der Luft.
 - Ausreichende Belüftung und Abstand zu Wärmequellen, einschließlich direktem Sonnenlicht
 - Ausreichender Abstand zu Quellen, die Erschütterungen oder Schläge/Stöße hervorrufen können
 - Isolierung von starken elektromagnetischen Feldern, wie sie durch Elektrogeräte erzeugt werden
 - Sicherer, abgeschlossener Arbeitsbereich mit beschränktem Zugang, sodass nur geschultes und qualifiziertes Servicepersonal Zugriff auf das Gerät hat
 - In für elektrische Stürme anfälligen Gebieten wird empfohlen, das System an einen Spannungsstoßunterdrücker anzuschließen.
 - Die Ausrüstung im unteren Teil des Gestells installieren, um zu vermeiden, dass der obere Teil des Gestells zu schwer wird.
 - Auf allen Seiten für mindestens 7,5 cm (3") Abstand sorgen, um eine ausreichende Belüftung zu gewährleisten. Die Lufteinlassöffnung an den vorderen, seitlichen und hinteren Entlüftungsgittern nicht blockieren. Das System nicht in der Nähe von Wärmequellen aufstellen.
- Sicherstellen, dass die Ausrüstung in einem Bereich aufgestellt wird, der den Spezifikationen für Leistungsaufnahme und Wärmeabstrahlung der Komponenten entspricht.
- Sicherstellen, dass Ihre Netzteile die Anforderungen an die Strom- oder Wechselstromversorgung vor Ort für alle Netzwerkgeräte erfüllen.
- Bei den NETGEAR-Produkten handelt es sich um digitale Geräte der Klasse A gemäß Teil 15 der FCC-Richtlinien und anderen internationalen Richtlinien. Der Gerätebetrieb

unterliegt den folgenden Voraussetzungen: (1) Das Gerät kann schädliche Interferenzen verursachen, und (2) das Gerät muss jede empfangene Interferenz zulassen, einschließlich einer Interferenz, die einen unerwünschten Betrieb verursachen kann.

Installation von Netzteilen



WARNING!

Bei der Installation sämtlicher Netzteile von NETGEAR muss sichergestellt werden, dass die nachfolgend aufgeführten Anforderungen erfüllt sind. Angaben zu Nennleistung und Leistungsbedarf finden sich in den Installationsanweisungen für das jeweilige Netzteil (Power Supply Unit, PSU).

Folgende Anforderungen müssen unbedingt erfüllt sein:

- Wenn der mit Wechsel- oder Gleichstrom betriebene Switch von NETGEAR mit einem externen grünen/gelben Erdungskabel ausgestattet ist, dann muss zunächst dieses Erdungskabel zwischen der Grundplatte und einem geeigneten Erdungspunkt angeschlossen werden, bevor andere Verbindungen zum Gerät hergestellt werden; dies gilt auch für den Anschluss an das Wechsel- bzw. Gleichstromnetz. Beim Ausbau des Geräts aus dem Gestell muss das Erdungskabel als letztes getrennt werden.
- Netzteile nur an vorschriftsmäßig geerdete Steckdosen anschließen, um die Gefahr elektrischer Schläge zu vermeiden und die Konformität mit internationalen Sicherheitsnormen zu gewährleisten.
- Nur Stromkabel verwenden, die für den Einsatz in dem jeweiligen Land zugelassen sind. Wechselstromkabel dürfen nicht manipuliert werden.
- Die Wandsteckdose muss in der Nähe der Anlage installiert und leicht zugänglich sein, um eine schnelle Trennung vom Netz zu ermöglichen.
- Spannung und Frequenz der Steckdose müssen den elektrischen Nenndaten des Systems entsprechen. Das Gebäude bzw. die Stromquelle muss mit einem Überlastschutz ausgestattet sein.
- Einen Spannungsstoßunterdrücker, einen Netzfilter oder eine unterbrechungsfreie Stromversorgung verwenden, um das System vor einer vorübergehenden Zu- oder Abnahme der elektrischen Leistung zu schützen.
- Bei laufendem Betrieb austauschbare Netzteile: Das Netzteil vorsichtig, nicht mit Kraft in das Aufnahmefach einsetzen.
- Bei Einsatz mehrerer Netzteile in einem Switch sind die Netzteile jeweils an unterschiedliche, unabhängige Stromquellen anzuschließen. Auf diese Weise ist bei einem Ausfall einer einzelnen Stromquelle nur das daran angeschlossene Netzteil betroffen. Wenn alle Netzteile eines einzelnen Switch an dieselbe Stromquelle angeschlossen sind, ist der gesamte Switch für einen Ausfall der Stromversorgung anfällig.

Leistungsspezifikationen für Netzteile von NETGEAR finden sich in Anhang B dieses Dokuments oder im Netzteil-Datenblatt unter <http://www.netgear.com>.



WARNING!

Die 325 W DC-Netzteile von NETGEAR sind nicht mit Ein-/Ausschaltern ausgestattet. Vor dem Einstecken des Gleichstromkabels in den Gleichstromanschluss des 325 W DC-Netzteils von NETGEAR sowie vor dem Abziehen des Kabels sicherstellen, dass der Gleichstromkreis abgeschaltet ist.

Das Gleichstromkabel des 325 W DC-Netzteils muss von einem qualifizierten, zugelassenen Elektriker an die Gleichspannungsquelle in Ihrem Gebäude angeschlossen werden.

NETGEAR 325 W AC Netzteile haben keinen An- Aus Schalter. Die Stromzufuhr zu einem NETGEAR 325 W AC Netzteil wird durch das Ziehen des Netzkabels unterbrochen. Es ist sicherzustellen dass diese Verbindung leicht zugänglich ist.

Das Netzteil nicht ausserhalb von dem Gehäuse an das Netz anschliessen da hierdurch gefährliche Spannungen zugänglich werden sowie die Gefahr von einem elektrischem Schlag und/ oder Feuergefahr besteht.

Nicht die Hand in den Netzteilschacht einführen wenn das Netzteil entfernt ist. Leere Netzteilschächte müssen immer mit eine Abdeckplatte bedeckt sein.

Wartungssicherheit

Folgende Vorsichtsmaßnahmen müssen getroffen werden:

- Nur für den Einsatz mit diesem System zugelassene Originalzubehöerteile bzw. -komponenten verwenden. Die Nichtbeachtung dieser Anweisungen kann zu Schäden an der Ausrüstung oder sogar zu einem Verstoß gegen die erforderlichen Sicherheitsbestimmungen und EMV-Vorschriften führen.
- Die Abdeckung der Grundplatte darf nur durch Personal von NETGEAR entfernt werden. Das System enthält keine vom Kunden zu wartenden Komponenten. Reparaturen am System sind von einem Werkstechniker von NETGEARs durchzuführen.
- Der An-/Aus-Schalter des Systems darf nicht die gesamte Stromversorgung zum System unterbrechen. Zur Unterbrechung der Wechselstromversorgung zum System müssen alle Stromkabel aus den Wandsteckdosen gezogen werden. Das Stromkabel dient zur Trennung von der Netzstromversorgung.

- Vor dem Entfernen der Rückwand eines NETGEAR-Switch muss die gesamte Stromzufuhr unterbrochen werden.
- Vor der Aufnahme von Arbeiten in der Nähe von Stromquellen alle Stromkabel abziehen, sofern nicht im Rahmen eines Wartungsverfahrens anders vorgegeben.
- Beim Umgang mit Modulen, optischen Geräten, Netzteilen oder anderen modularen Zubehörteilen das ESD-Schutzarmband anlegen, um das Risiko einer Beschädigung der Geräte durch elektrostatische Entladungen zu verringern. Das Armband zum Schutz elektrostatisch gefährdeter Bauteile (ESB) grundsätzlich an der Grundplatte befestigt lassen, damit es beim Umgang mit diesen Bauteilen immer zur Hand ist.
- Alle Kabel so verlegen, dass übermäßige Belastungen vermieden werden. Kabelbinder oder Zugentlastungsklemmen verwenden.
- Ein Stromkabel bei Anzeichen von Beschädigungen unverzüglich austauschen.

Allgemeine Sicherheitsvorkehrungen

Folgende Richtlinien sind unbedingt zu befolgen:

- Keine Gegenstände heben, die möglicherweise zu schwer sind.
- Bei einer Installation in einem Gestell darauf achten, dass schwere Geräte unten im Gestell eingebaut werden, um Gefahren durch Umkippen zu vermeiden.
- Bei Summit Desktop-Switches keinen Monitor oder andere Gegenstände auf die Anlage stellen. Die Abdeckung der Grundplatte ist nicht darauf ausgelegt, Gewicht zu tragen.
- Nur Werkzeuge und Ausrüstung verwenden, die sich in einwandfreiem Zustand befinden. Keine Ausrüstung verwenden, die sichtbare Beschädigungen aufweist.
- Verlegen von Kabeln: Kabel so verlegen, dass keine Schäden entstehen oder Unfälle, z. B. durch Stolpern, verursacht werden können.

Auswahl der Stromkabel

Je nachdem, welchen Switch Sie erworben haben, werden die Wechselstromnetzteile von NETGEAR entweder nur mit einem 110-VAC-Kabel oder mit einem 110-VAC-Kabel und einem 208/220-VAC-Kabel geliefert. Die von NETGEAR gelieferten Stromkabel sind nur für den Einsatz in den Vereinigten Staaten und Kanada ausgelegt und zugelassen. Stromkabel für den Einsatz außerhalb der Vereinigten Staaten und Kanada werden normalerweise von einem Drittanbieter geliefert und müssen die folgenden Anforderungen erfüllen:

- Die Stromkabel müssen offiziell für das Land zugelassen sein, in dem sie verwendet werden sollen.
- Die Stromkabel müssen mit einem für das Einsatzland zugelassenen Wandsteckkontakt mit der geeigneten Nennleistung ausgerüstet sein.
- Die Konfiguration der Steckvorrichtung (die Steckverbindung zur Einheit, nicht zur Wandsteckdose) muss für eine Gerätesteckdose gemäß EN60320/IEC320-C14 ausgeführt sein.
- Die Länge der Stromkabel muss weniger als 5 m (15 Fuß) betragen.

- Die Mindestspezifikation für das flexible Kabel lautet:
 - Nr. 18 AWG (0,823 mm²) für Einheiten mit einem Bemessungsstrom von weniger als 10 A, oder
 - Nr. 18 AWG (0,823 mm²) bis 2 m Länge für Einheiten mit einem Bemessungsstrom von 10 A oder höher, oder
 - Nr. 16 AWG (1,0 mm²) bis 5 m Länge für Einheiten mit einem Bemessungsstrom von 10 A oder höher
- Bei allen Kabeln muss es sich um 3-adrige Kupferleiter vom Typ SVT oder SJT, HAR oder einen äquivalenten Typ handeln.

Verwenden Sie immer ein Wechselstromkabel, das den Vorschriften Ihres Landes entspricht. Erkundigen Sie sich über die örtlichen Vorschriften für Elektroinstallationen und fragen Sie bei den zuständigen Aufsichtsbehörden nach den Anforderungen an Stromkabel. Nähere Angaben zu den Leistungsspezifikationen von Netzteilen finden sich unter <http://www.netgear.com> oder in Anhang B dieses Dokuments.



WARNING!

Vor dem Anschließen des Wechselstromkabels an ein Netzteil muss sichergestellt werden, dass die Steckdose vorschriftsgemäß geerdet ist.

Hinweis: Die Bauvorschriften sind weltweit verschieden; NETGEAR empfiehlt daher ausdrücklich, einen Elektroinstallateur zu beauftragen, um die sachgemäße Geräteerdung und Stromverteilung für Ihre spezifische Installation sicherzustellen.

Austauschen und Entsorgen von Batterien

Im Umgang mit Batterien sind folgende Hinweise zu beachten:

- Austauschen der Lithium-Batterie: Die in diesem Gerät enthaltenen Batterien können nicht vom Anwender ausgetauscht werden. Wenden Sie sich für einen Austausch des kompletten Gerätes bitte an die Servicemitarbeiter von NETGEAR. Sollte der Versuch eines Austausches unternommen werden, sind zur Vermeidung einer Explosionsgefahr folgende Richtlinien zu beachten:
 - a Die Batterie nur durch eine identische oder eine gleichwertige, vom Hersteller empfohlene Batterie ersetzen.
 - b Die Batterie gemäß den Empfehlungen des Herstellers entsorgen.

Lichtleiteranschlüsse: Optische Sicherheit



WARNING!

Beim Umgang mit Lichtleitermodulen sind folgende Vorsichtsmaßnahmen zu beachten:

- Niemals durch ein Vergrößerungsgerät auf die übertragende LED/den Laser schauen, wenn diese(r) eingeschaltet ist.
- Niemals direkt auf einen Lichtleiteranschluss am Switch oder auf die Enden eines Faserkabels schauen, wenn diese eingeschaltet sind.
- Bei offenen Anschlüssen kann es zu unsichtbarer Laserstrahlung kommen. Direkter Augenkontakt mit dem Strahl ist zu vermeiden.
- Ein optisches Gerät niemals auf andere Weise verändern oder modifizieren als in diesem Dokument angegeben.

Einhaltung behördlicher Vorschriften durch GBIC, SFP (Mini-GBIC), XENPAK und XFP

- Laserprodukt der Klasse 1
- EN60825-1+A2:2001 oder jünger, Europäische Richtlinie für Lasersysteme
- Anwendung der CE-Kennzeichnung gemäß der Richtlinien 89/336/EWG EMV und 73/23/EWG für Niederspannungsgeräte

B. Technical Specifications

B

This appendix includes the following technical specifications:

- *8800 Series Chassis Switch XCM8810* on page 120
- *8800 Series Chassis Switch XCM8806* on page 123
- *Modules for 8800 Series Switches* on page 125
- *700 W Power Supply* on page 126
- *Connector Pinouts* on page 126

8800 Series Chassis Switch XCM8810

Table 10. 8800 Series Chassis Switch XCM8810 Technical Specifications

Physical characteristics	
XCM8810 chassis	Height: 24.47 inches (62.2 cm) Width: 17.51 inches (44.5 cm) Depth: 18.23 inches (46.3 cm) Weight (empty): 79 lb (35.8 kg) Weight (fully loaded): 196 lb (88.9 kg)
Fan tray XCM8810FT	Weight: 6.75 lb (3.06 kg) Minimum fan speed: 500 RPM Maximum fan speed: 6000 RPM
Power supply XCM88PS1	Weight: 7 lb (3.2 kg)
PSU/fan controller XCM88FPB	Weight: 1.75 lb (.79 kg)
Safety standards	
North American Safety of ITE	UL 60950-1:2003 1st Ed., Listed Device (US) CSA 22.2#60950-1-03 1st Ed.(Canada) Complies with FCC 21CFR 1040.10 (US Laser Safety) CDRH Letter of Approval (US FDA Approval) NOM/NYCE (Mexico) IEEE 802.3af 6-2003 Environment A for PoE Applications
European Safety of ITE	EN 60950-1:2001+A11 EN 60825-1+A2:2001 (Lasers Safety) TUV-R GS Mark by German Notified Body 73/23/EEC Low Voltage Directive
International Safety of ITE	CB Report & Certificate per IEC 60950-1:2001 Country Deviations AS/NZX 60950-1(Australia /New Zealand)
EMI/EMC Standards	
North America EMC for ITE	FCC CFR 47 part 15 Class A (USA) ICES-003 Class A (Canada)
European EMC standards	EN 55022:1998 Class A EN 55024:1998 Class A includes IEC 61000-4-2, 3, 4, 5, 6, 8, 11 EN 61000-3-2,3 (Harmonics & Flicker) ETSI EN 300 386:2001 (EMC Telecommunications) 89/336/EEC EMC Directive

Table 10. 8800 Series Chassis Switch XCM8810 Technical Specifications (Continued)

International EMC Certifications	<p>CISPR 22:1997 Class A (International Emissions) CISPR 24:1997 Class A (International Immunity) IEC/EN 61000-4-2 Electrostatic Discharge, 8kV Contact, 15kV Air, Criteria A IEC/EN 61000-4-3 Radiated Immunity 10V/m, Criteria A IEC/EN 61000-4-4 Transient Burst, 1kV, Criteria A IEC/EN 61000-4-5 Surge, 2kV, 4kV, Criteria A IEC/EN 61000-4-6 Conducted Immunity, 0.15-80MHz, 10V/m unmod. RMS, Criteria A IEC/EN 61000-4-11 Power Dips & Interruptions, >30%, 25 periods, Criteria C</p>
Country-specific	<p>VCCI Class A (Japan Emissions) AS/NZS 3548 ACA (Australia Emissions) CNS 13438:1997 Class A (BSMI-Taiwan) MIC Mark, EMC Approval (North Korea)</p>
Telecom Standards	<p>ETSI EN 300 386:2001 (EMC Telecommunications) ETSI EN 300 019 (Environmental for Telecommunications)</p>
<p>IEEE 802.3 Media Access Standards</p> <p>Note: These standards are module-specific and may not apply to every module in the series.</p>	<p>IEEE 802.3 10BASE-T IEEE 802.3u 100BASE-TX, 100BASE-FX IEEE 802.3z 1000BASE-X IEEE 802.3ab 1000BASE-T IEEE 802.3ac VLAN Tag IEEE 802.3ad Link Aggregation IEEE 802.3ae 10GBASE-X IEEE 802.3aef Power over Ethernet</p>
Environmental Data	
Environmental standards	<p>EN/ETSI 300 019-2-1 v2.1.2 - Class 1.2 Storage EN/ETSI 300 019-2-2 v2.1.2 - Class 2.3 Transportation EN/ETSI 300 019-2-3 v2.1.2 - Class 3.1e Operational EN/ETSI 300 753 (1997-10) - Acoustic Noise ASTM D3580 Random Vibration Unpackaged 1.5G</p>
Operating conditions	<p>Operating temperature range: 0° C to 40° C (32° F to 104° F) Operating humidity: 10% to 93% relative humidity, non-condensing Operational shock: 30 m/s² (3 g), 11 ms, 60 shocks Operational sine vibration: 5 to 100 to 5 Hz @ 0.2 g, 0 to peak, 0.1 oct./min. Operational random vibration: 3 to 500 Hz @ 1.5g rms</p>
Storage & transportation conditions (packaged)	<p>Transportation temperature: -40° C to 70° C (-40° F to 158° F) Storage and transportation humidity: 10% to 93% relative humidity, non-condensing Packaged shock (half sine): <50 kg 180 m/s² (10 g), 6 ms, 600 shocks, modules >50 kg 100 m/s² (6 g), 11 ms, 600 shocks, chassis Packaged random vibration: 5 to 20 Hz @ 1.0 ASD w/-3 dB/oct. from 20 to 200 Hz 14 drops minimum on sides & corners @ 39.5" <22 lb (10 kg) modules @ 11.8" <110 lb (50 kg) chassis</p>

Table 10. 8800 Series Chassis Switch XCM8810 Technical Specifications (Continued)

Acoustic Sound	
Sound power in accordance with EN 300 753 (10-1997)	Sound power Normal: 70 dBA per ISO 7779 High: 75 dBA per ISO 7779 Declared sound power Normal: 7.2 belsA per ISO 7779 & ISO 9296 High: 7.7 belsA per ISO 7779 & ISO 9296
Sound pressure in accordance with NEBS GR-63 Issue 2	Bystander sound pressure Normal: 64 dBA front side @ 0.6m High: 67 dBA rear side @ 0.6m

8800 Series Chassis Switch XCM8806

Physical Characteristics	
XCM8806 chassis	Height: 17.47 inches (44.4 cm) Width: 17.51 inches (44.5 cm) Depth: 18.12 inches (46.0 cm) Weight (empty): 63.75 lb (29.0 kg) Weight (fully loaded): 153 lb (69.5 kg)
Fan tray XCM8806FT	Weight: 4.75 lb (2.2 kg) Minimum fan speed: 500 RPM Maximum fan speed: 6000 RPM
Power supply XCM88PS1	Weight: 7 lb (3.2 kg)
PSU/fan controller XCM88FPB	Weight: 1.75 lb (.79 kg)
Safety Standards	
North American Safety of ITE	UL 60950-1:2003 1st Ed., Listed Device (US) CSA 22.2#60950-1-03 1st Ed.(Canada) Complies with FCC 21CFR 1040.10 (US Laser Safety) CDRH Letter of Approval (US FDA Approval) NOM/NYCE (Mexico) IEEE 802.3af 6-2003 Environment A for PoE Applications
European Safety of ITE	EN 60950-1:2001+A11 EN 60825-1+A2:2001 (Lasers Safety) TUV-R GS Mark by German Notified Body 73/23/EEC Low Voltage Directive
International Safety of ITE	CB Report & Certificate per IEC 60950-1:2001 Country Deviations AS/NZX 60950-1 (Australia /New Zealand)
EMI/EMC Standards	
North America EMC for ITE	FCC CFR 47 part 15 Class A (USA) ICES-003 Class A (Canada)
European EMC standards	EN 55022:1998 Class A EN 55024:1998 Class A includes IEC 61000-4-2, 3, 4, 5, 6, 8, 11 EN 61000-3-2,3 (Harmonics & Flicker) ETSI EN 300 386:2001 (EMC Telecommunications) 89/336/EEC EMC Directive
International EMC certifications	CISPR 22:1997 Class A (International Emissions) CISPR 24:1997 Class A (International Immunity) IEC/EN 61000-4-2 Electrostatic Discharge, 8kV Contact, 15kV Air, Criteria A IEC/EN 61000-4-3 Radiated Immunity 10V/m, Criteria A IEC/EN 61000-4-4 Transient Burst, 1kV, Criteria A IEC/EN 61000-4-5 Surge, 2kV, 4kV, Criteria A IEC/EN 61000-4-6 Conducted Immunity, 0.15-80MHz, 10V/m unmod. RMS, Criteria A IEC/EN 61000-4-11 Power Dips & Interruptions, >30%, 25 periods, Criteria C

Country-specific	VCCI Class A (Japan Emissions) AS/NZS 3548 ACA (Australia Emissions) CNS 13438:1997 Class A (BSMI-Taiwan) MIC Mark, EMC Approval (North Korea)
Telecom Standards	ETSI EN 300 386:2001 (EMC Telecommunications) ETSI EN 300 019 (Environmental for Telecommunications)
IEEE 802.3 Media Access Standards Note: These standards are module-specific and may not apply to every module in the series.	IEEE 802.3 10BASE-T IEEE 802.3u 100BASE-TX, 100BASE-FX IEEE 802.3z 1000BASE-X IEEE 802.3ab 1000BASE-T IEEE 802.3ac VLAN Tag IEEE 802.3ad Link Aggregation IEEE 802.3ae 10GBASE-X IEEE 802.3aef Power over Ethernet
Environmental Standards	
Environmental	EN/ETSI 300 019-2-1 v2.1.2 - Class 1.2 Storage EN/ETSI 300 019-2-2 v2.1.2 - Class 2.3 Transportation EN/ETSI 300 019-2-3 v2.1.2 - Class 3.1e Operational EN/ETSI 300 753 (1997-10) - Acoustic Noise
Operating conditions	Operating temperature range: 0° C to 40° C (32° F to 104° F) Operating humidity: 10% to 93% relative humidity, non-condensing Operating altitude 0 to 3000 meters (0 to 9,850 ft) Operational shock: 30 m/s ² (3 g), 11 ms, 60 shocks Operational random vibration: 5 to 500 Hz @ 1.5g rms
Storage & transportation conditions (packaged)	Transportation temperature: -40° C to 70° C (-40° F to 158° F) Storage and transportation humidity: 10% to 93% relative humidity, non-condensing Packaged shock (half sine): <50 kg 180 m/s ² (10 g), 6 ms, 600 shocks, modules >50 kg 100 m/s ² (6 g), 11 ms, 600 shocks, chassis Packaged random vibration: 5 to 20 Hz @ 1.0 ASD w/-3 dB/oct. from 20 to 200 Hz Packaged sinusoidal vibration: 5 to 62 Hz, 5 mm/s velocity, 62 to 200 Hz, 0.2 g Tilt: 22.5 degrees and return to position 14 drops minimum on sides & corners @ 39.4" <20 lb (9 kg) modules @ 19.7" <80 lb (36 kg) chassis
Acoustic Sound	
Sound power in accordance with EN 300 753 (10-1997)	Sound power Normal: 70 dBA per ISO 7779 High: 73 dBA per ISO 7779 Declared sound power Normal: 7.2 belsA per ISO 7779 & ISO 9296 High: 7.6 belsA per ISO 7779 & ISO 9296
Sound pressure in accordance with NEBS GR-63 Issue 2	Bystander sound pressure Normal: 64 dBA front side @ 0.6m High: 66 dBA left side @ 0.6m

Modules for 8800 Series Switches

Table 11. Specifications for 8800 Series Modules and Option Cards

Modules	
All modules	Dimensions: 1.63 in. H x 15.26 in. W x 5.25 in. D] (4.1 cm x 38.8 cm x 38.7 cm)
Supervisory module XCM88S1	Weight: 6.45 lb (2.93 kg) Power: 150 W (heat dissipation 512 BTU)
8800 Series 48-port 10/100/1000 Base-T Module XCM8848T	Weight: 7.75 lb (3.52 kg) Power: 110 W (module only) (heat dissipation 376 BTU) Power with installed PoE card: 110 W (Heat Dissipation 376 BTU)
8800 Series PoE Daughter Card for XCM8848T XCM88P	Weight: 6.91 lb (3.13 kg) Power: 135 W (Heat Dissipation 461 BTU)
8800 Series 8-port 10GBase-XFP Module XCM8808X	Weight: 6.95 lb (3.15 kg) Power: 100 W (heat dissipation 341 BTU)
Option cards	
8800 Series 8-port 1000Base-X SFP Card XCM888F for Supervisory module	Dimensions: 1.32 inches H x 6.94 inches W x 11.19 inches D (3.35 cm x 17.63 cm x 28.42 cm) Weight: 2.20 lb (1.0 kg)
PoE daughter card XCM88P	Dimensions: 1.25 in. H x 14.31 in. W xy 4.81 in. D (3.18 cm x 36.35 cm x 12.22 cm) Weight: 0.80 lb (0.36 kg)

700 W Power Supply

Table 12. Specifications for the 100-240VAC Power Supply Unit

Typical configuration	3 power supplies
Full configuration	6 power supplies
Input	Nominal input: 100 to 240 V \sim , 60/50 Hz, 10 A max AC voltage input range: 90 to 264 V \sim Maximum input amperages: 7 A @ 200 V \sim (high-line) 10 A @ 90 V \sim (low-line) AC line frequency: 47 to 63 Hz PS input socket: IEC 320 C14 Minimum wire size: 16 AWG (1.31mm ²) copper stranded
Output	DC output: 48 V \equiv , 24 A/12 V \equiv , 4 A (high-line) 48 V \equiv , 13.5 A/12 V \equiv , 4 A (low-line) DC output power (W): 700 to 1200 W
Power supply cord selection	Refer to Selecting Power Supply Cords on page 109.
AC power supply input socket	IEC 320 C14
Minimum wire size	18 AWG (0.75 mm ²) up to 6 feet or 2 meters or 16 AWG (1.0 mm ²) over 6 feet
Operating conditions	Operating temperature: 0° C to 40° C Storage temperature: -40° C to 70° C Operating humidity: 10% to 90% relative humidity, non-condensing Operational shock: 30 m/s ² (3 g)

Connector Pinouts

The following table describes the pinouts for a DB-9 console plug connector.

Table 13. Pinouts for the DB-9 Console Connector

Function	Pin Number	Direction
DCD (data carrier detect)	1	In
RXD (receive data)	2	In
TXD (transmit data)	3	Out
DTR (data terminal ready)	4	Out
GND (ground)	5	-
DSR (data set ready)	6	In

Table 13. Pinouts for the DB-9 Console Connector (Continued)

Function	Pin Number	Direction
RTS (request to send)	7	Out
CTS (clear to send)	8	In

The following figure shows the pinouts for a 9-pin to 25-pin (RS-232) null-modem cable.

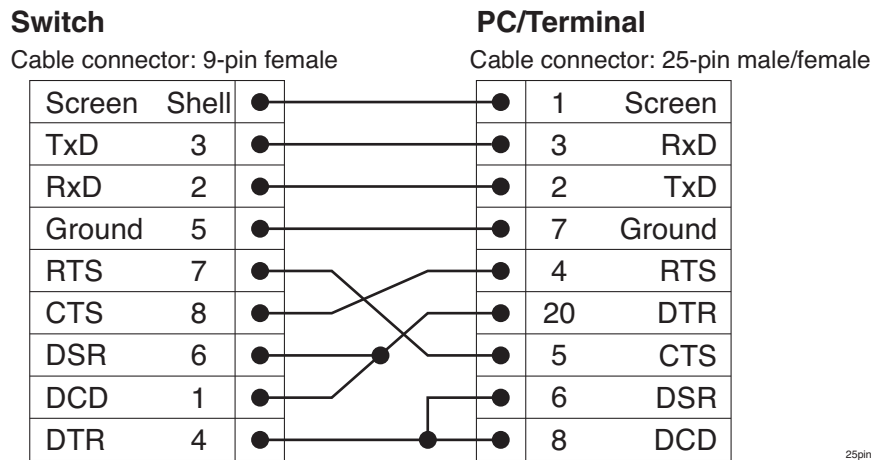

Figure 74. Null-modem Cable Pinouts

The following figure shows the pinouts for a 9-pin to 9-pin (PC-AT) null-modem serial cable.

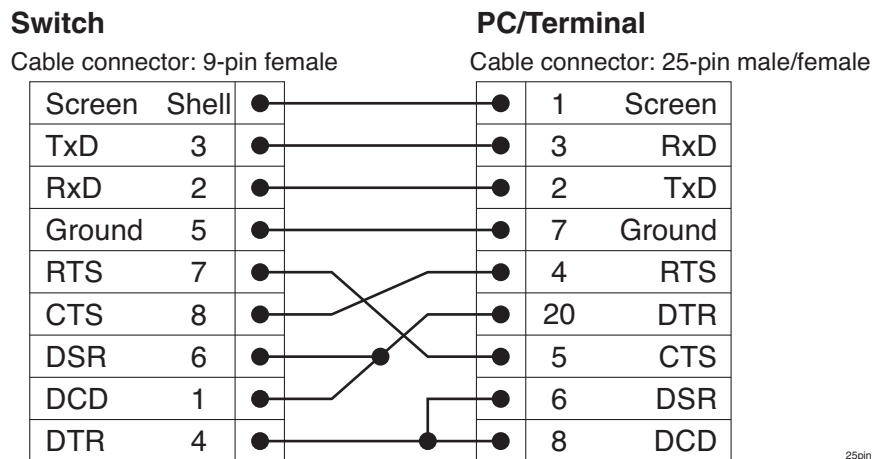
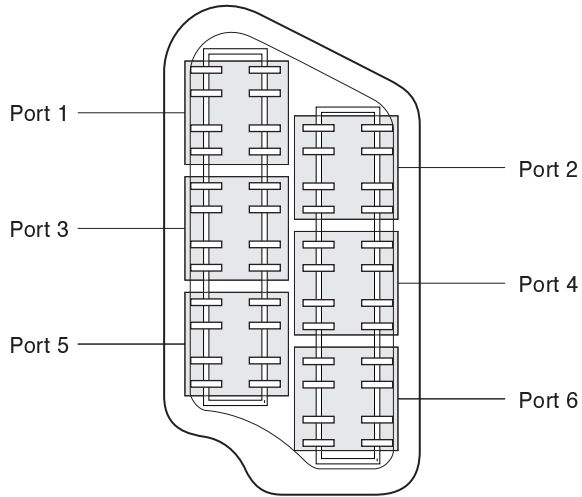

Figure 75. PC-AT Serial Null-modem Cable Pinouts

The following figure shows the port assignments for the MRJ21 connector.



BD_232

Figure 76. Port-to-Pin Assignments in the MRJ21 Connector

Index

Numerics

- 8000 Series modules
 - distinguishing Supervisory module from I/O **61**
 - installing **60**
- 8800 Series chassis switch
 - blank front panels **68**
 - features **8**
 - grounding terminals, location **32**
 - rack measurement **42**

A

- A button, Supervisory module **15**
- AC power cord retainer
 - XCM8806 switch
 - installing **84**
 - removing **87**
 - XCM8810 switch
 - installing **82**
 - removing **84**
- acoustic sound specifications
 - XCM8806 switch **124**
 - XCM8810 switch **122**
- alternate BootROM image **15**
- amperage, calculating for UPS **41**
- ANSI standards **41**

B

- bend radius
 - fiber optic cable **37**
 - UTP cable **36**
- BICSI standards **33**
- blank front panels, installing **68**
- building codes **28**
- Building Industry Consulting Service International.
See BICSI
- bundling cable **36**

C

- cable
 - bend radius
 - fiber optic **37**

- UTP **36**
- Category 5 **37**
- fiber optic **37**
- installing **36**
- slack **36**
- types and distances **35**
- cable clips **92**
- cable connections, making **65**
- cable holder **90**
- cable labeling **34**
- cable management **37, 89**
- cabling standards
 - ANSI **41**
 - BICSI **33**
- Category 5 cable **37**
- chassis unpacking
 - XCM8806 **43–45**
 - XCM8810 **45–47**
- chassis-to-chassis heating **29**
- commands
 - eject memorycard **71**
 - show memorycard **71**
 - show slot **66**
 - synchronize **65**
- commercial building standards **41**
- compact flash. See external memory card
- components, installing
 - AC power cord retainer
 - XCM8810 switch **82**
 - backup Supervisory module **65**
 - blank front panel **68**
 - external memory card **71**
 - fan tray **95**
 - PoE daughter card **75**
 - PSU/fan controller **99**
 - Supervisory module option card **77**
- components, removing
 - AC power cord retainer
 - XCM8806 switch **87**
 - XCM8810 switch **84**
 - external memory card **71**
 - fan tray **93**
 - I/O modules **66**
 - PoE daughter card **77**
 - PSU/fan controller **97**

- Supervisory module **66**
- Supervisory option card **79**

- connectors
 - DB-9 **126**
 - MRJ21 **128**

- console port
 - description **15**
 - pinouts **126**
 - settings **72**

D

- D button, Supervisory module **15**
- daughter card, PoE **75**
- DB-9 pinouts **126**
- design standards **41**
- distribution rack. *See* equipment rack

E

- electrical codes **28**
- electrostatic discharge. *See* ESD
- EMI/EMC standards **120, 123**
- environmental requirements
 - airflow **30**
 - building codes **28**
 - electrical codes **28**
 - humidity **29**
 - switch spacing **29**
 - temperature **29**
 - wiring closet **28**
- environmental standards **121**
- equipment rack
 - grounding **32**
 - mechanical recommendations **31**
 - mounting holes **31**
 - securing **33**
 - service access **32**
 - space requirements **32**
- ESD
 - discharge from cable **37**
 - system protection **31**
- ESD-preventive wrist strap **31**
- external compact flash slot **14**
- external memory card
 - installing or removing **71**
 - uses **9**

F

- fan tray
 - installing **95**
 - removing **93**

- fiber optic cable
 - bend radius **37**
 - care **38**
 - connections, making **65**

- first switch login **72**
- full-duplex **8**

G

- grounding
 - chassis **50**
 - racks **32**
 - requirements **41**
 - wiring closet provisions **29**
- grounding terminals, location **32**

H

- handles on Supervisory modules and I/O modules **64**
- heating, chassis-to-chassis **29**
- high-line power **25**
- hot-swapping modules **66**
- humidity requirements **29**

I

- I/O modules
 - description **17**
 - hot-swapping **66**
 - injector/ejector handles **64**
 - installing **62**
 - LEDs **20**
 - removing **66**
 - specifications **125**
 - verifying installation **65**
 - XCM8808X **19**
 - XCM8824F **19**
 - XCM8848T **18**
- identification records, cable **34**
- IEEE 802.3 media access standards **121, 124**
- industry standards **41**
- initial switch login **72**
- inline power
 - I/O module **18**
 - LEDs **21**
- installation
 - 8800 Series chassis switch **48**
 - AC power supply **56**
 - blank front panels **68**
 - modules **62**
 - POE daughter card **75**
 - PSU/fan controller **99**
 - Supervisory module option cards **77**
- IP settings, configuring **72**

L

labeling system for cables **34**

LEDs

I/O modules **20**

PoE ports **21**

ports **21**

power supply unit **24**

logging in to the switch **72**

low-line power **25**

M

MAC address

XCM8806 switch **10**

XCM8810 switch **12**

management port **8, 15**

management, cable **89**

mechanical recommendations for rack **31**

memory card. *See* external memory card

mid-mount installation. *See* rack installation

modules, installing **62**

mounting holes, rack **31**

N

network interface connections, making **65**

null-modem cable pinouts **127**

O

operating conditions **121**

See also environmental requirements

operating environment requirements. *See* environmental requirements

option cards

features **16**

See also daughter card

specifications **125**

over-current conditions, preventing **25**

P

PC-AT serial null-modem cable pinouts **127**

pinouts

DB-9 console connector **126**

MRJ21 connector **128**

null-modem cable **127**

PC-AT serial null-modem cable **127**

plenum-rated cable **36**

PoE

daughter card, installing **75**

port LEDs **21**

PoE daughter card

weight **125**

PoE devices, power requirements **39**

ports

console **15**

console port settings **72**

management **8, 15**

See also individual module descriptions

power cable

AC, connecting **58**

requirements **40**

Power over Ethernet. *See* PoE

power requirements

PoE devices **39**

power cable **40**

power supplies **39**

power supplies

AC, installing **56**

airflow **30**

power requirements **39**

PSU

description **23**

power supply unit

LEDs **24**

removing **58**

PSU/fan controller

installing **99**

removing **97**

R

R button, Supervisory module **15**

rack installation **48**

rack mounting holes **31**

rack specifications

grounding **32**

mechanical **31**

space requirements **32**

radio frequency interference. *See* RF interference

removing PSU/Fan controller **97**

repacking

XCM8810 switch **102**

requirements

airflow **30**

chassis spacing **29**

grounding **32**

humidity **29**

space **32**

reset button, Supervisory module **15**

RF interference

patch panel installation **36**

preventing **38**

problems caused by **38**

RJ-45 cable [35](#)
RJ-45 connector jackets [35](#)
running cable. See cable, installing

S

safety requirements [106](#)
 See also environmental requirements
safety standards [123](#)
securing rack to floor [33](#)
serial number
 XCM8806 switch [10](#)
 XCM8810 switch [12](#)
service access to the rack [32](#)
site planning process [27](#)
slack, cable [36](#)
slot assignments [61](#)
space requirements, rack [32](#)
specifications
 modules [125](#)
 option cards [125](#)
 XCM8810 switch [120](#)
specificationsXCM8810 switch [120](#)
standards
 cabling [33](#), [41](#)
 commercial building [41](#)
 grounding [41](#)
 rack [31](#)
storage conditions [121](#), [124](#)
Supervisory module
 booting [14](#)
 console port [15](#)
 dual Supervisory modules [14](#)
 external compact flash slot [14](#)
 front panel [15](#)
 hot-swapping [66](#)
 installation verification [65](#)
 LEDs [16](#)
 management port [15](#)
 primary, backup functionality [14](#)
 removing [66](#)
 saving configurations [14](#)
 slot assignments [61](#)
 specifications [125](#)
Supervisory module reset [15](#)
support bracket [48](#)
switch configuration, saving [14](#)
switch spacing requirements [29](#)
system dump [15](#)

T

technical specifications

 modules [125](#)
 option cards [125](#)
 XCM8810 switch [120](#)
technical support [2](#)
telecom standards [121](#), [124](#)
temperature, wiring closet [29](#)
tools, installation
 AC power cord retainer [82](#), [84](#)
 AC PSU [56](#)
 blank front panel [68](#)
 chassis [48](#)
 external memory card [71](#)
 fan tray [93](#)
 PoE daughter card [75](#)
 PSU/fan controller [97](#)
 Supervisory module option card [77](#)
trademarks [2](#)
transition time, UPS [40](#), [41](#)
transportation conditions [121](#), [124](#)
troubleshooting
 external memory card, installing [71](#)
 over-current conditions [25](#)
 power, turning off [25](#)
 RF interference [38](#)

U

uninterruptible power supply. *See* UPS
unshielded twisted pair. *See* UTP
UPS
 amperage requirements, calculating [41](#)
 description [40](#)
 features [40](#)
 selecting [40](#)
 size, determining [41](#)
 transition time [40](#), [41](#)
UTP cable
 bend radius [36](#)
 Category 5 [37](#)
 discharge ESD [37](#)
 RF interference [38](#)

W

weight
 chassis components [123](#)
wiring closet
 airflow requirements [30](#)
 electrostatic discharge [30](#)
 floor coverings [28](#)
 grounding [29](#)
 humidity [29](#)
 rack, securing [33](#)
 temperature [29](#)

X

- XCM8806 switch
 - bandwidth **9**
 - features **9**
 - grounding **50**
 - grounding terminals, location **51**
 - MAC address **10**
 - mid-mount installation **49**
 - replacing fan tray **93**
 - serial number **10**
 - unpacking **43**
- XCM8808X module
 - features **19**
- XCM8810 switch
 - AC power cord retainer
 - installing **82**
 - removing **84**
 - bandwidth **11**
 - features **11**
 - grounding terminals, location **51**
 - MAC address **12**
 - repacking **102**
 - replacing fan tray **93**
 - serial number **12**
 - specifications **120**
 - unpacking **45**
- XCM8824F module
 - features **19**
 - LEDs **20**
- XCM8848T module
 - features **18**
 - LEDs **20**
- XCM888F option card
 - features **16**
 - installing **77**